

Product Brochure For ZA350

Superseded Model - Hydraulic Engine CraneSydney Garage Sale
Pickup Only

ORDER CODE:	A350
MODEL:	HC-1T
Type:	Engine Crane
Brand:	HAFCO
Capacity:	1 Tonne
Speed Range (rpm):	~
Motor Power (kW / hp):	~
Voltage / Amperage (V / amp):	~
Branch The Item is Located (Available):	Sydney

**Description**

Freight will apply from others warehouses

Every mechanic or home auto restoration enthusiast knows all too well by using the correct tool it always makes the job in hand much easier with a more successful outcome when it is time to remove or replace an engine in your car. It can also be used to lift machines or other heavy items, making for an excellent piece of equipment for the workshop or warehouse.

This HC-1T engine crane has an 8-tonne long stroke lifting ram with a double acting pump, and this crane has been tested up to 2 tonne capacity allowing a maximum safe working load lift capacity of 1000kg. The jib extends to four different positions with the desired lifting capacity of 250kg, 500kg, 750kg or 1000kg and secured by a single locking pin.

The lifting height range is from 0-2300mm so an engine can be lifted & removed clear out of the engine bay with little effort. The long & wide legs provide great floor stability and the 6 swivel castor wheels & rear T-bar handle enables excellent manoeuvrability around the workshop. Another nifty feature with this crane is that you can quickly fold up the long legs to save on storage space in the workshop.

Features

- Double action pump on hydraulic 8 tonne lifting ram
- Ideal for automotive, light engineering and general workshop
- Adjustable boom in four positions for lifting
- Outrigger legs easily folded up for transport or storage
- Six cast steel swivel caster wheels allow easy mobility
- T-bar handle with grips on rear of hoist allows greater manoeuvrability control
- Supplied with a short lifting chain & hook with safety latch
- Tested to 2 tonne capacity

Product Brochure For ZA350

Specific Features



ZA350



Includes Double Action Pump



HC-1T



Dimensions

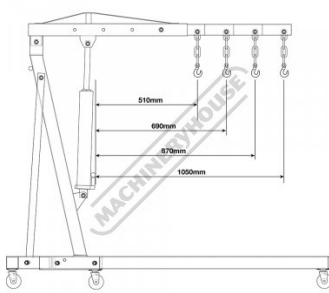

Throat Depth

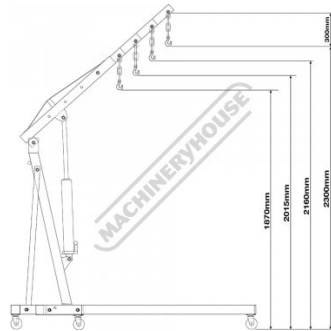

Max Lift Settings



Shown Folded Up



Shown With Beam down



Beam Fully up



Beam Fully Up and Extended



Front View



Rear View



Ram



Boom Adjustable Settings



Handle For Easy Manoeuvrability



Slide Out Beam

Product Brochure For ZA350



Lifting Chain



Hand Operated Pump



Double Action Pump

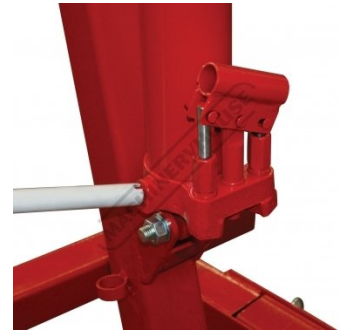

Ram Release Valve



Fold Up Legs Release Pins



Fold Up Legs with Pins



Swivel Wheels



Operating Instructions

Recommended Accessories

A3425
Engine Tilter - Heavy Duty



J032
Hydraulic Bottle Jack with Yoke
- 8 Tonne

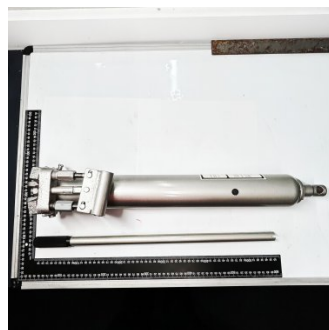

A340
Engine Stand - 907kg Capacity



A341
Engine Stand - 450kg Capacity



Product Brochure For ZA350

A385
Steel Gearbox & Engine Tear
Down Table



H300
Round Sling



H305
Round Sling



H307
Round Sling



H310
Round Sling



H312
Round Sling



H316
Flat Sling



H318
Flat Sling



H320
Flat Sling



H322
Flat Sling



H324
Flat Sling

