

Product Brochure For W1026

UM125PM-C3 - 4 In One Utility Clamping System

320mm Clamping Capacity
1100kg Clamping Force

Ex GST
\$230.00

Inc GST
\$264.50

ORDER CODE:	W1026
MODEL:	UM125PM-C3
Type:	Utility Clamp
Clamping Capacity:	320mm
Locking Handle - Pivot Movement:	~
Clamp Bar - Pivot Movement:	~
Plunger Travel (mm):	~
Throat Depth (mm):	140
Opening (mm):	~
Size:	~
Quantity Per Pack (No.):	~
Clamping Force (kg):	1100kg
Over all Length (mm):	~
Nett Weight (kg):	3.5



Description

ONE CLAMP FOUR FUNCTIONS:

The most versatile & economical sliding arm clamp available. Each clamp comes complete with a V-Pad and Extender Block. The threaded hole on the base simply allows the attachment to screw & lock into position.

Sliding Arm Clamps with the Removable / Reversible Clamp Arm and Unique Accessories

Professional Quality at an Affordable Price.

Features

- Made of heat treated alloy steel and nickel/chrome plated for strength and durability
- Sliding arm clamps are 10x faster than conventional C-clamps
- The exclusive V-Pad enable pipe clamping
- Reverse the clamp arm and attachment to create a spreader clamp
- The extender block allows step over clamping with ease

Includes

- The three piece 4-in-1 Clamp Kit includes:
- Sliding Arm Clamp
- Extended Block
- V-Pad

Product Brochure For W1026

Specific Features



V Pad Jaw



With Extender Block Jaw



Clamping With Step Over

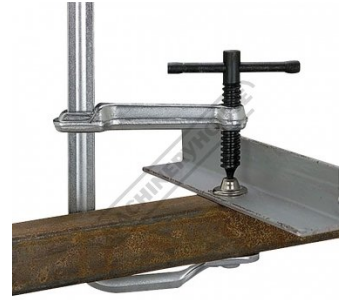

Clamping Steel



Clamping Steel Pipe



Shown As Spreader

Recommended Accessories

W1028
4 In One Utility Clamping System

W1027
4 In One Utility Clamping System

C0010
Ratchet F Clamp

W1005
Snake Magnet & Spring Clamp



Product Brochure For W1026

W1006
Adjust-O Magnet Square - Heavy Duty



W1007
Adjust-O Magnet Square - Heavy Duty



W1009
Mini Magnet Squares - (2-Pack)



W1010
Corner Magnets - (2-Pack)



W1011
XYZ Magnet Squares - Multi-Angle - (2-Pack)



W1012
Adjustable Corner Clamping Plier Set



W1013
Corner Clamping Plier



W1014
Pipe Plier - Large

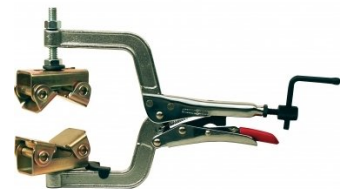

W1015
Pipe Plier



W1016
Locking C-Clamp - Round Tip



W1017
Locking C-Clamp - Swivel Tip



W1018
Locking C-Clamp - Swivel Tip



Product Brochure For W1026

W112

Micro Welding Steel Clamp Set



W113

Butt Welding Aluminium & Steel
Clamp Set

