

Product Brochure For W07971

## BuildPro Magspring Clamp - UDV65M

83mm Throat Depth  
115mm Opening



**Limited Stock**

Ex GST  
**\$44.00**

Inc GST  
**\$50.60**

ORDER CODE:	W07971
MODEL:	UDV65M
Type:	Magspring Clamp
Clamping Capacity:	~
Locking Handle - Pivot Movement:	~
Clamp Bar - Pivot Movement:	~
Plunger Travel (mm):	~
Throat Depth (mm):	83
Opening (mm):	115mm
Size:	~
Quantity Per Pack (No.):	~
Clamping Force (kg):	225kg
Over all Length (mm):	~
Nett Weight (kg):	0.5

**BuildPro™**



### Description

Quick-Set Clamps for fast, convenient clamping.

The spring-loaded, one-handed clamp with quick-set magnetic V-Pad. Squeeze to open, set in position and turn to tighten. 225kg clamping pressure.

- The Spring Loaded Arm allows users to free up one hand to position the workpiece.
- Once positioned, the Adjustable Magnetic V-Pad holds the clamp to the workpiece for tightening.

The very practical, modular design of the BuildPro®; Table makes it easy to set-up and tear down for job at hand, big or small. Save time and money by holding, positioning and locating quickly and easily with a wide variety of BuildPro®; clamps and accessories.

All BuildPro®; Tables have 16mm thick steel plate with &Oslash;16mm holes in a 50mm grid pattern. All tables, except BuildPro®; MAX, have 40mm slots between plates.

Product Brochure For W07971

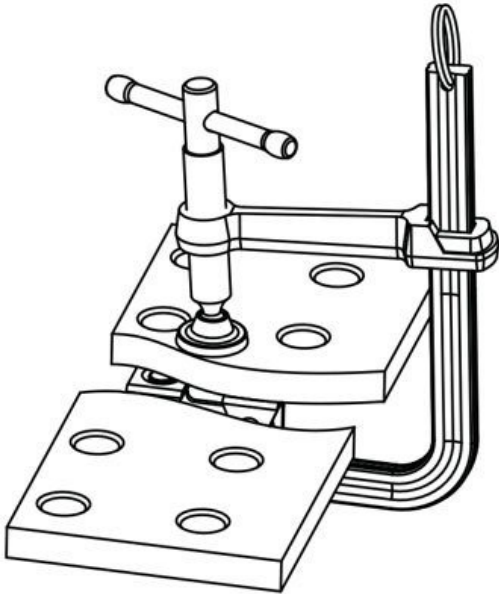

Magnetic V-Pad keeps  
Clamp in position on  
steel surfaces.

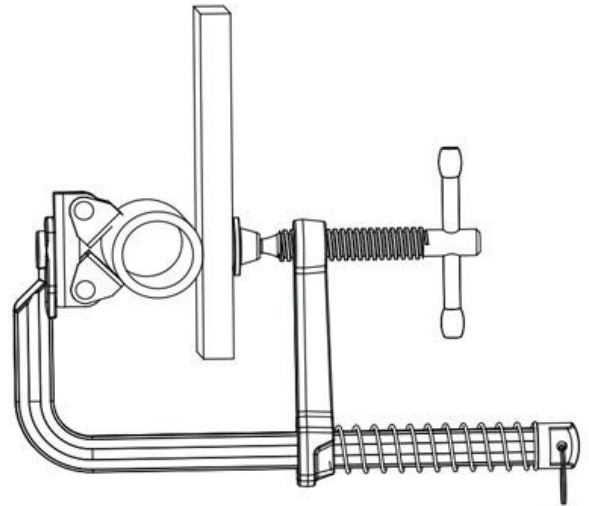

V-Pad adjusts to hold  
round, flat, and angled  
steel surfaces.

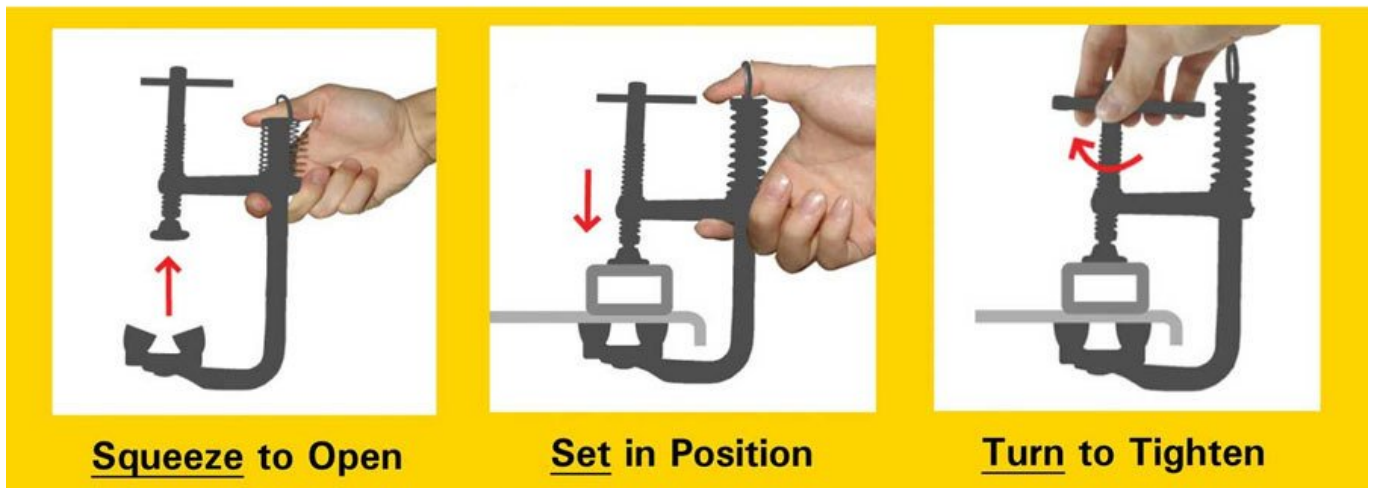

Squeeze to Open

Set in Position

Turn to Tighten

Product Brochure For W07971

**Specific Features**



Shown Using Additional Fixtures



Shown Clamping Tube



Clamping Round to Square



Spring Loaded Arm

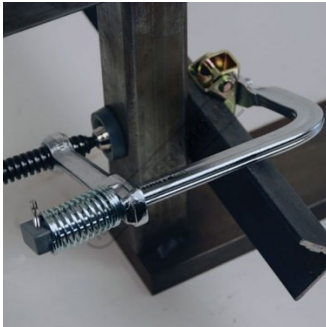

Clamping Angle to Square

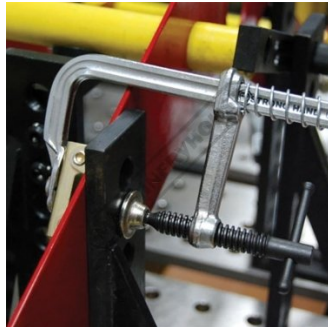

Shown Clamping Plate



Instantly adjusts for Different Shapes Round Flat and Angle Steel Surfaces



the Magspring Holds onto Metal Wood and Synthetic Materials