

Product Brochure For W07807

800 x 1200mm M16 Pro Series LIFT Welding Table - WT16-1208LIFT

500kg Total W.L.L.
Ø16mm Holes

Ex GST **Inc GST**
\$3,282.00 **\$3,774.30**



ORDER CODE:	W07807
MODEL:	WT16-1208LIFT
Table Hole Diameter (Ø):	16
Table Top Finish (Type):	Plasma Nitriding Coating
Table Top Size (mm):	800 x 1200
Grid Pattern (mm/Type):	50 x 50 / Standard
Table Height (mm):	440-960
Table Side Height (mm):	50 / 65
Top Plate Thickness (mm):	12
Table Slots (mm):	~
Static Load Capacity (kg):	~
Total W.L.L. (kg):	500
Number of Legs (No.):	~
Nett Weight (kg):	262.60



Description

The WT16-1208T Metalmaster M16 Pro Series LIFT Welding Table is the ultimate mobile welding solution, built for strength, precision and versatility.

With a foot-operated lever for smooth height adjustment, it offers an adjustable height range of 440mm to 960mm, providing optimal ergonomics and comfort for any welding task. With its Ø150mm swivel caster & 500kg load capacity ensures it can handle a wide range of jobs, from small-scale projects to heavy-duty industrial work.

The 800 x 1200mm table top is constructed from a welded S355 steel frame, CNC-machined for precise flatness. Featuring Ø16mm holes with a 50 x 50mm hole pattern, it offers versatile clamping options for fixtures. Solid steel ribs and 50mm high sides enhance rigidity, while the plasma nitriding coating provides resistance to spatter, wear, and rust.

Features

- Adjustable in height via a foot-operated lever from 440-960mm for ergonomic use
- 800 x 1200mm 3D Welding Tabletop with Ø16mm precision bored fixing holes
- 50 x 50mm hole grid pattern offering a multitude of clamping options
- Plasma nitriding surface finish for increased hardness, rust & spatter resistance
- Tabletop is manufactured from heavy S355 plate steel
- CNC machined to ensure flatness
- Total WLL = 500kg weight capacity
- Removeable push handle for easy maneuvering
- Ø150mm swivel casters with 2 brake wheels for secure positioning
- Safety locking pin with 4 positions
- Includes galvanized steel dust tray

Product Brochure For W07807

Specific Features



Table At Highest Setting



Table At Lowest Setting



Safety Locking Pin



Hydraulic Foot Controls



Removable Handle



Slide Out Tray



Safety Lock Pin Holder

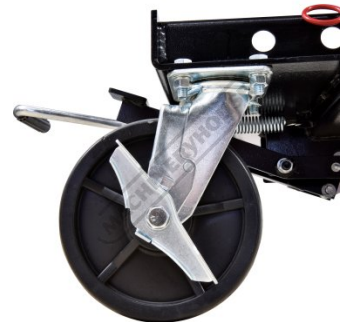

Lockable Caster Wheels

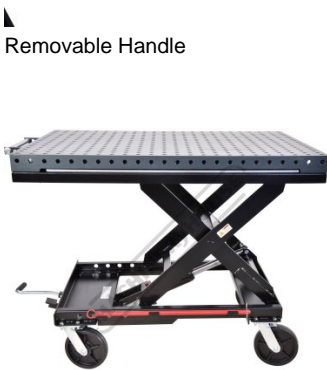

Side View



Low View



800 x 1200mm 3D Welding Tabletop

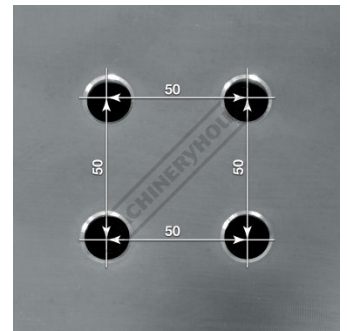

50 x 50mm Hole Centre Pattern



Plasma Nitride table surface treatment

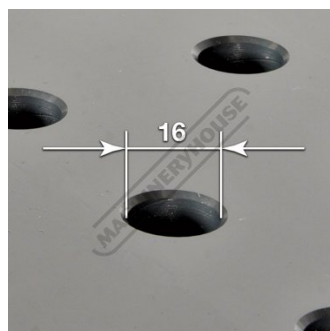

Ø16mm Diameter Holes



12mm Table Thickness

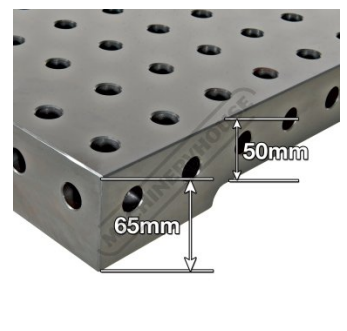

65mm High Ends with 50mm High Sides

Product Brochure For W07807



Strengthened by Welded Webbing

Recommended Accessories

W07814

52pc Pro Series Welding Table Clamp Kit

W07815

70pc Pro Series Welding Table Clamp Kit

W07816

93pc Pro Series Welding Table Clamp Kit

W07817

120pc Pro Series Welding Table Clamp Kit

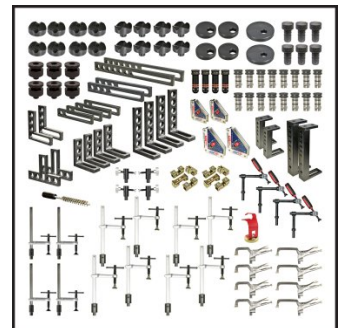
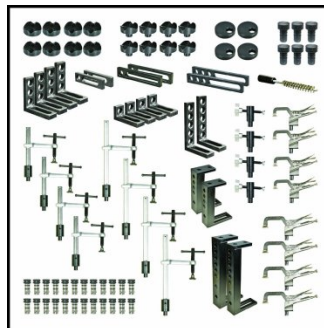
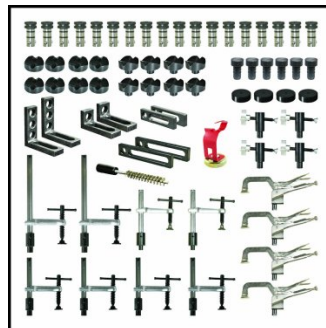
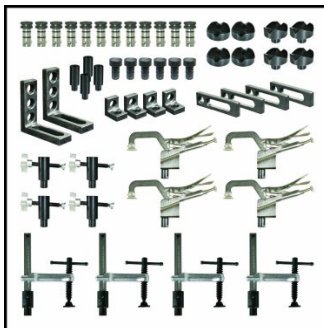

W07818

151pc Pro Series Welding Table Clamp Kit

