

Product Brochure For W07805

800 x 1200mm M16 Pro Series Welding Table Cart - WT16-1208C

500kg Total W.L.L.
Ø16mm Holes

New Release

Ex GST

Inc GST

\$2,868.00

\$3,298.20



ORDER CODE:	W07805
MODEL:	WT16-1208C
Table Hole Diameter (Ø):	16
Table Top Finish (Type):	Plasma Nitriding Coating
Table Top Size (mm):	800 x 1200
Grid Pattern (mm/Type):	50 x 50 / Standard
Table Height (mm):	900
Table Side Height (mm):	50 / 65
Top Plate Thickness (mm):	12
Table Slots (mm):	~
Static Load Capacity (kg):	~
Total W.L.L. (kg):	500
Number of Legs (No.):	~
Nett Weight (kg):	180



Description

The WT16-1208C Metalmaster M16 Pro Series Welding Table Cart is our economical version for a mobile welding solution, built for strength, precision and versatility.

With sturdy 70 x 70mm square tube legs providing a solid working surface for any welding tasks. With its Ø125mm swivel caster & 500kg load capacity ensures it can handle a wide range of jobs, from small-scale projects to heavy-duty industrial work.

The 800 x 1200mm table top is constructed from a welded S355 steel frame, CNC-machined for precise flatness. Featuring Ø16mm holes with a 50 x 50mm hole pattern, it offers versatile clamping options for fixtures. Solid steel ribs and 50mm high sides enhance rigidity, while the plasma nitriding coating provides resistance to spatter, wear, and rust.

Features

- 800 x 1200mm 3D Welding Tabletop with Ø16mm precision bored fixing holes
- 50 x 50mm hole grid pattern offering a multitude of clamping options
- Plasma nitriding surface finish for increased hardness, rust & spatter resistance
- Tabletop is manufactured from heavy S355 plate steel
- CNC machined to ensure flatness
- Sturdy 70 x 70mm square steel legs with Ø125mm swivel casters with 2 brake wheels for secure positioning
- A working height of 900mm for ergonomic use
- Total WLL = 500kg weight capacity
- Includes galvanized steel dust tray

Product Brochure For W07805

Specific Features



Full View Pull Out Tray



Top View with Tray Removed

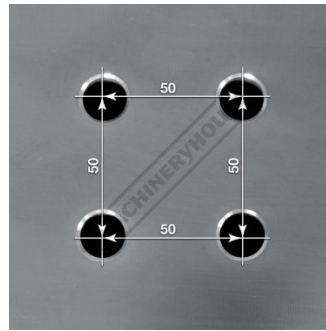

50 x 50mm Hole Centre Pattern

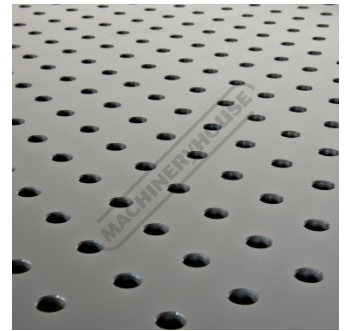

Plasma Nitride table surface treatment

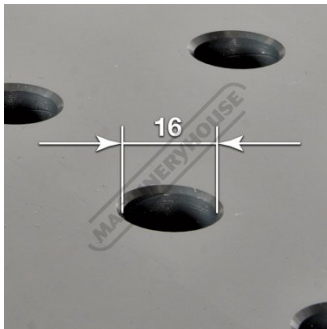

Ø16mm Diameter Holes

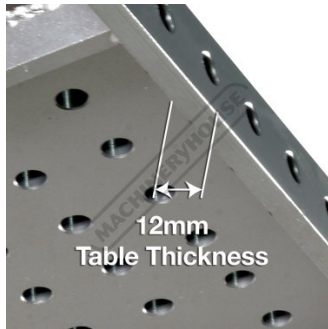

12mm Table Thickness

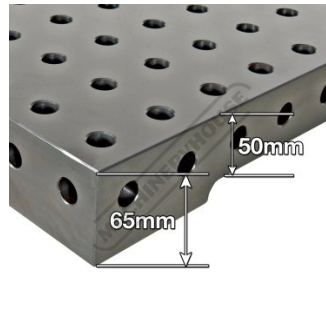

65mm High Ends with 50mm High Sides



Feet with 4 Mounting Holes



Strengthened by Welded Webbing



Welding Table



Heavy Duty Steel Legs 70 x 70mm



Heavy Duty Swivel Brake Wheels



Pull Out Tray Close Up



Pull Out Tray Table Top



Side View



End View

Product Brochure For W07805



Front View



Side View Shown with Optional Drawer Unit A423



Side Low View Shown with Optional Drawers A423

Recommended Accessories

A422

2 Drawer - Industrial Under Bench Tooling Cabinet



A423

3 Drawer - Industrial Under Bench Tooling Cabinet



W07814

52pc Pro Series Welding Table Clamp Kit

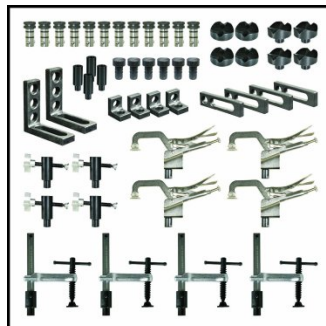

W07815

70pc Pro Series Welding Table Clamp Kit

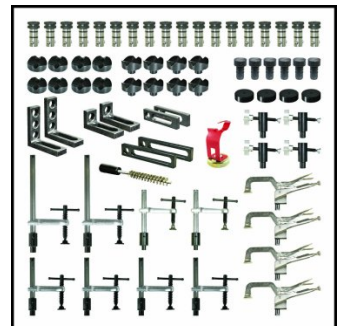

W07816

93pc Pro Series Welding Table Clamp Kit

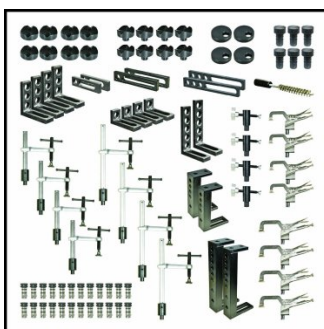

W07817

120pc Pro Series Welding Table Clamp Kit

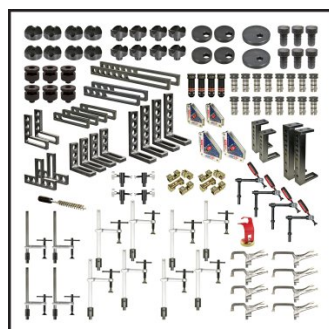

W07818

151pc Pro Series Welding Table Clamp Kit

