

Product Brochure For W07804

## 2000 x 1000mm M16 Pro Series Welding Table - WT16-2010

Ø16mm Holes



<b>Ex GST</b>	<b>Inc GST</b>
<b>\$4,698.00</b>	<b>\$5,402.70</b>

ORDER CODE:	W07804
MODEL:	WT16-2010
Table Hole Diameter (Ø):	16
Table Top Finish (Type):	S355 plate steel
Table Top Size (mm):	2000 x 1000
Grid Pattern (mm/Type):	50 x 50 / Standard
Table Height (mm):	900
Table Side Height (mm):	100
Top Plate Thickness (mm):	12
Table Slots (mm):	~
Static Load Capacity (kg):	2000
Total W.L.L. (kg):	~
Number of Legs (No.):	4
Nett Weight (kg):	315



### Description

The Metalmaster M16 Pro Series welding tables features a welded & ribbed construction from heavy S355 plate steel, the frame is then CNC machined with the sides & top having a finished nominal thickness of 12mm. The CNC machining process is able to achieve a high flatness tolerance of +/- 0.1mm over 1m<sup>2</sup> to give you a smooth precision welding surface. During this CNC machining process, the Ø16mm holes are precision bored to ensure a hole distance tolerance of +/- 0.05mm & with an industry standard 50 x 50mm hole pattern it gives you a multitude of fixture holes to suit your application. Before removing the table from the machining centre, we engrave 50mm grid lines to give you millimetre precision helping you minimise mistakes while increasing productivity.

Our Pro Series tables have been designed with interlocking solid steel ribs & 100mm high sides to maintain rigidity with substantial load capacity for all medium sized fabrication projects. The hole spacing is an industry standard 50mm giving you almost endless possibilities for both welding and clamping applications. The table also comes complete with powder coated round steel tube legs complete with levelling feet ensuring a stable working surface.

This model is designed for those budget minded customers wanting a table the same tolerances & accuracy as our deluxe M16 Pro Series range but without all the bells & whistles of the nitride coating & perimeter engraving.

Choose from our wide range of optional Pro Series clamping kits & fixturing accessories to add to your table giving you the ultimate welding & fixturing system so when you go into battle with your next fabrication project it's a knockout.

### Features

- Tabletop & sides manufactured from heavy S355 plate steel
- Precision CNC machined to ensure flatness of +/- 0.1mm over 1m<sup>2</sup>
- Ø16mm Precision bored fixing holes at 50mm centres
- 50 x 50mm hole grid pattern offering a multitude of clamping options
- 50mm engraved grid lines

### Includes

- 4pcs of round steel legs c/w adjustable leveling feet

Product Brochure For W07804

**Specific Features**



50x50mm Hole Centres Pattern

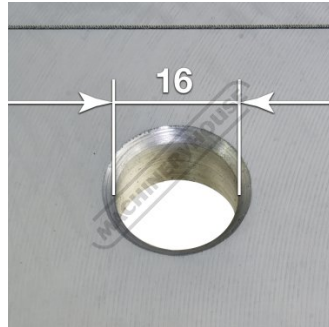

16mm Diameter Holes



Table Manufactured from Heavy S355 Plate Steel

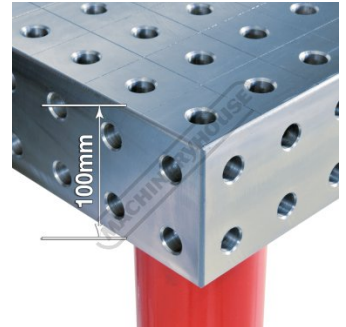

100mm Sides

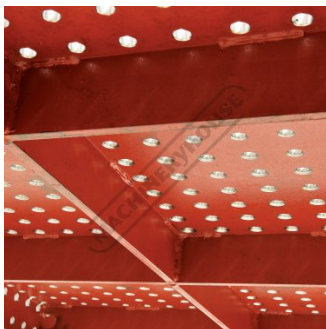

Strengthened by Welded Webbing



Adjustable Feet

**Recommended Accessories**

W07814

52pc Pro Series Welding Table Clamp Kit

W07815

70pc Pro Series Welding Table Clamp Kit

W07816

93pc Pro Series Welding Table Clamp Kit

W07817

120pc Pro Series Welding Table Clamp Kit

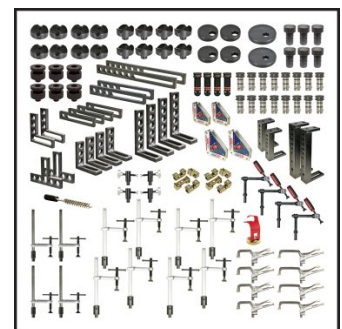
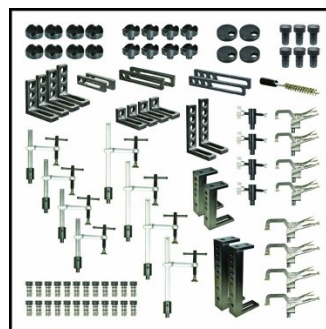
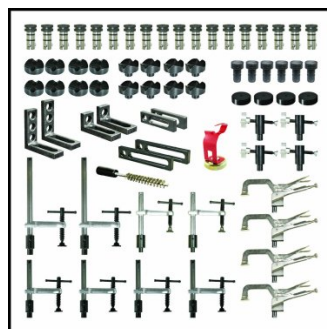
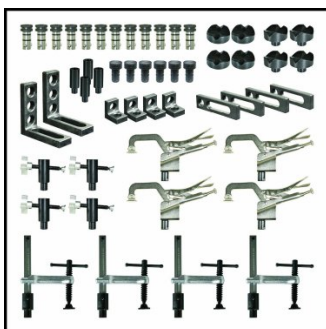

Product Brochure For W07804

---

W07818

151pc Pro Series Welding Table  
Clamp Kit

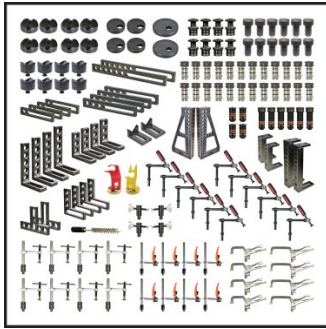

W07820

Table & Accessory Lifting Kit

