

## Product Brochure For V312A

### Modular Machine Vice

203mm Jaw Width

400mm Jaw Opening

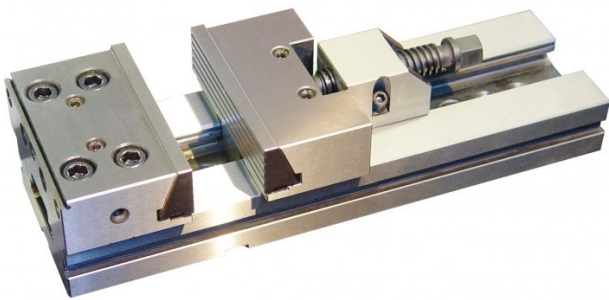

ORDER CODE:	V312A
A - Jaw Width (mm):	203
C - Jaw Opening (mm):	400
B - Jaw Height (mm):	65
D (mm):	695
E (mm):	810
F (mm):	70
G (mm):	170
H (mm):	114
Nett Weight (kg):	75

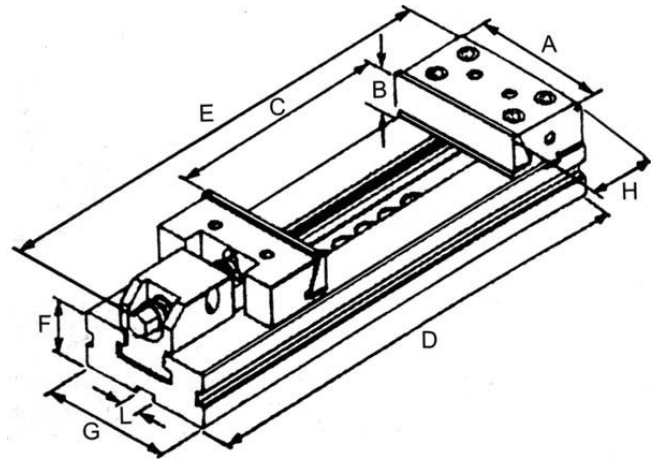

#### Description

Toolmaster vices are manufactured under rigid quality control. All Toolmaster vices are interchangeable and can be used as matched pairs.

#### Features

- Hardened and ground steel to HRC60, with high precision
- Keyways are 16mm H7 and are toleranced giving perfect alignment and reducing set up time
- Space saving design allows for maximum use of clamping area