

Product Brochure For V3114

Tilting Vice Base

Suits 125 & 150mm Modular Vices
0-90°



ORDER CODE:	V3114
A - Jaw Width (mm):	~
C - Jaw Opening (mm):	~
B - Jaw Height (mm):	~
D (mm):	340
E (mm):	~
F (mm):	80
G (mm):	125
H (mm):	~
Nett Weight (kg):	30

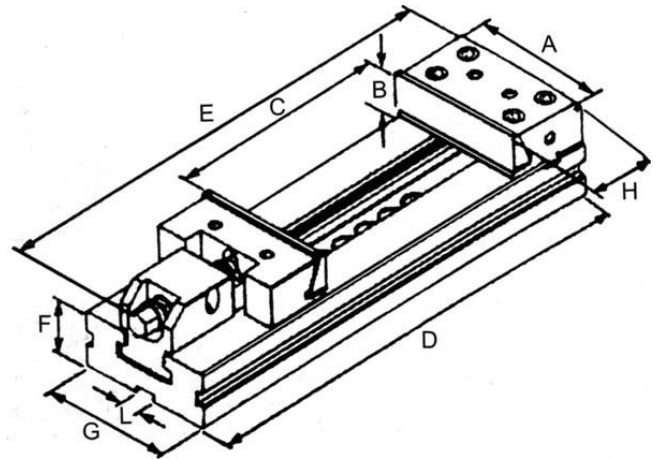

Features

- Hardened and ground steel
- Has mounting bolt holes for both 125 & 150mm vices
- Comes complete with 4 clamping blocks
- Base tilts from 0 to 90°
- Positive clamping

Product Brochure For V3114

Specific Features



Shown Flat



Shown with Optional Vice

Recommended Accessories

V311
Modular Machine Vice

V311A
Modular Machine Vice

