

## Product Brochure For V3105

### Modular Machine Vice

125mm Jaw Width  
150mm Jaw Opening

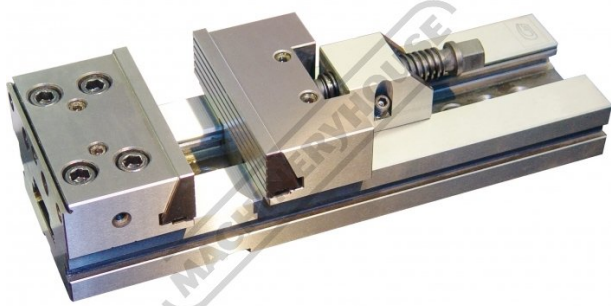

ORDER CODE:	V3105
A - Jaw Width (mm):	125
C - Jaw Opening (mm):	150
B - Jaw Height (mm):	40
D (mm):	345
E (mm):	365
F (mm):	40
G (mm):	95
H (mm):	~
Nett Weight (kg):	13

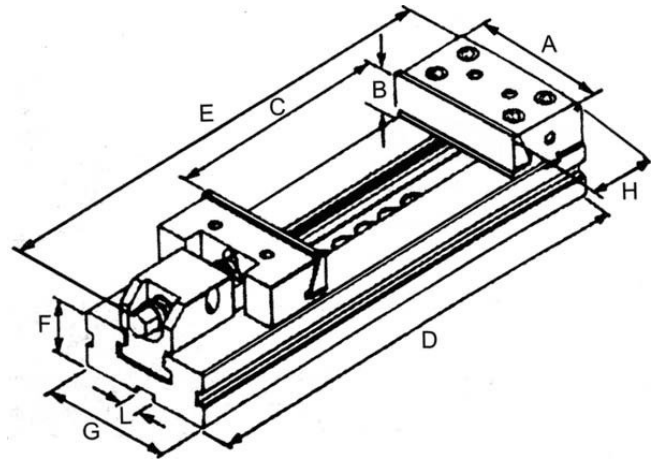

#### Description

Toolmaster vices are manufactured under rigid quality control. All Toolmaster vices are interchangeable and can be used as matched pairs.

#### Features

- Hardened and ground steel to HRC60, with high precision
- Keyways are 16mm H7 and are toleranced giving perfect alignment and reducing set up time
- Space saving design allows for maximum use of clamping area