

Product Brochure For V101

90 degree Angle Vice Clamp with Swivel Top Clamp - AC-100TC

Jaw Width - 2 x 90mm, Bottom Clamp
100mm Jaw Opening

Ex GST Inc GST
\$270.00 \$310.50

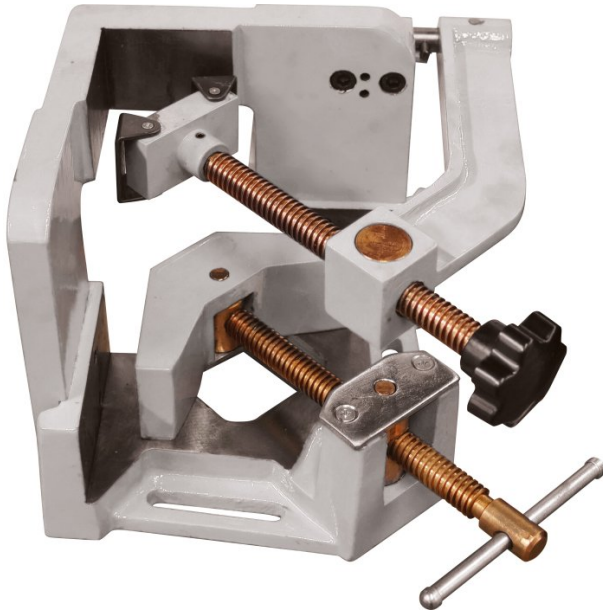

ORDER CODE:	V101
MODEL:	AC-100TC
Jaw Width (mm):	90
Jaw Opening (mm):	100
Jaw Height - Bottom Clamp (mm):	60
Overall Jaw Height - Includes Top Clamp (mm):	190
Nett Weight (kg):	25



Description

This rugged cast iron mitre clamps is just the job for heavy duty clamping metal sections for prep welding. The jaws are pivoted on the end of the copper coated screw that allows for a large degree of misalignment when clamping work pieces of different thickness. They can be used for mitre or T joints and with equal or odd material thicknesses. All the clamping surfaces, including the bases, are machined at 90°.

Features

- Jaws self-align to securely hold the same or different thickness materials always at 90°
- Bottom & top clamps round, square, angle-Iron, rectangle & channel sections
- Top clamp swivels up & out for convenience

Product Brochure For V101

Specific Features



Shown with Top Clamp in Upright Position



Shown With Box Tubing



Included Larger Clamp Attachment