

Product Brochure For T055

Manual Tube Bender - Round & Square - TBRS-25

Ø9.52 - Ø22.22mm Round Tube Capacity, 19.05 & 25.4mm Square
Tube Capacity, Ø12.7, Ø14.29, Ø15.87, Ø19.05, Ø22.22mm Round
& 19.05 & 25.4mm Square Formers

On Sale

Ex GST

Inc GST

\$320.00

\$368.00

\$250.43

\$288.00



ORDER CODE:	T055
MODEL:	TBRS-25
Material (Type):	Tube
Material Section (Type):	Round & Square
Machine (Type):	Manual
Hydraulic Jack Size (Tonne):	~
Round Pipe Range (NB) - Mild Steel (inch / mm):	~
Round Tube Range (OD) - Mild Steel (inch / mm):	Ø9.52 - Ø22.22
Square Tube Range (inch / mm):	19.05 & 25.4
Tube Wall Thickness - Mild Steel (inch / mm):	1.2
Round Pipe (NB) x Wall Capacity - Mild Steel (inch):	~
Round Pipe (NB) x Wall Capacity - Aluminium (inch / mm):	~
Round Pipe (NB) x Wall Capacity - Stainless Steel (inch / mm):	~
Round Tube (OD) x Wall Capacity - Mild Steel (inch / mm):	~
Round Tube (OD) x Wall Capacity - Aluminium (inch / mm):	~
Round Tube (OD) x Wall Capacity - Copper, Brass (inch / mm):	~
Round Tube (OD) x Wall Capacity - Stainless Steel (inch / mm):	~
Round Tube (OD) x Wall Capacity - Chromoly (inch / mm):	~
Solid Rod - Mild Steel (inch / mm):	~
Square Tube x Wall Capacity - Mild Steel (inch / mm):	~
Rectangle Tube x Wall Capacity - Mild Steel (inch / mm):	~
Bend Speed - Maximum (Deg / Sec):	~
Bend Direction:	~
Centre Line Radius - Maximum (CLR) (inch / mm):	~
Centre Line Radius - Minimum (CLR) (inch / mm):	~
Tube Formers Included (inch / mm):	9.52, 12.7, 14.29 Round & 15.87, 19.05, 22.22 Round & 19.05 & 25.4 Square
Pipe Formers Included (inch / mm):	~
Spigot Size on Ram (inch / mm):	~
Angle Capacity (deg):	0 - 180°
Hydraulic Pressure - Maximum (psi):	~
Motor Power (kW / hp):	~
Voltage / Amperage (V / amp):	~
Nett Weight (kg):	28

Description

This Hafco TBRS-25 tube bending kit has everything that you need to make smooth bends in round & Square tubes up to 1.2mm maximum wall thickness. Firstly, mount the cast iron base securely onto your work bench top or clamp it into a bench vice, then you are ready to begin your bend.

This great package is capable of bending round tubes from Ø9.52, Ø12.7, Ø14.29, Ø15.87, Ø19.05 & Ø22.22mm, and square tube from 19.05 & 25.4mm. Everything is all neatly packed into a handy storage carry case for your convenience,

Features

Product Brochure For T055

- Suitable for 1.2mm wall thickness in mild steel
- Cast Steel Round formers included: Ø9.52, Ø12.7, Ø14.29, Ø15.87, Ø19.05, Ø22.22mm
- Cast Steel Square formers included: 19.05 & 25.4mm

Includes

- Cast Steel Round Tube Formers:
 - D = Ø9.52mm OD - R = 47.5mm Centreline radius
 - D = Ø12.7mm OD - R = 57.5mm Centreline radius
 - D = Ø14.29mm OD - R = 67.5mm Centreline radius
 - D = Ø15.87mm OD - R = 77.25mm Centreline radius
 - D = Ø19.05mm OD - R = 88.25mm Centreline radius
 - D = Ø22.22mm OD - R = 107.25mm Centreline radius
- Cast Steel Square Tube Formers:
 - H = Ø19.05mm OD - L = 85mm Internal radius
 - H = Ø25.4mm OD - L = 92.5mm Internal radius

Specific Features



Carry Case



Bar Bender

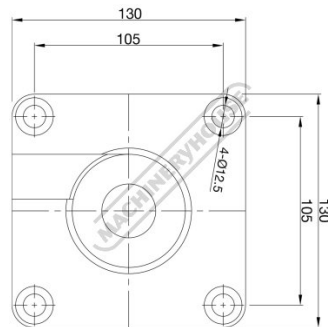

Base Dimensions

Recommended Accessories

B8119

Pipe/Tube Bending Lube -
475ml



M977

Digital Bevel Box

