

Product Brochure For S908G

Hydraulic NC Pressbrake - PB-135B

135T x 4000mm - Includes Light Curtain Safety Guarding
Estun NC-E21 Control 2-Axis with Hardened Ballscrew Backgauge



| | |
|--|----------------------|
| ORDER CODE: | S908G |
| MODEL: | PB-135B |
| Control Unit (Type): | Estun NC-E21 |
| Nominal Pressure - Tonnage (Ton): | 135 |
| Nominal Pressure - Kilonewtons (kN): | 1250 |
| Length of Work Table (mm): | 4000 |
| Distance Between Columns (mm): | 3200 |
| Throat Depth (mm): | 415 |
| Maximum Open Height (mm): | 390 |
| Ram Stroke (mm): | 130 |
| Machine Axis (No.): | 2 |
| Safety Guarding System (Type): | Light Curtain System |
| Backgauge Travel (mm): | 520 |
| Table Bed Crowning System (Type): | - |
| Motor Power (kW / hp): | 7.5 / 10 |
| Motor Voltage (V): | 415 |
| Floor Space Requirements (L x W x H) (mm): | 4700 x 2000 x 2700 |
| Nett Weight (kg): | 10350 |



Description

MetalMaster Pressbrakes are manufactured in partnership with Hare and Forbes for a worldwide market, they are used and accepted from first time user's right through to established manufacturers.

MetalMaster Quality Pressbrakes feature high durability, and provide precision bending capabilities. The Pressbrake main frames are constructed from rolled, stress relieved solid steel to prevent distortion during the bending process and under extreme continuous loads.

MetalMaster Pressbrakes are produced in a high volume production process and therefore are able to be manufactured cost effectively, resulting in affordable price, representing value for money and quicker return on investment.

Featuring an adjustable synchronised torsion bar with positive stop system ensures consistent and accurate bending beam parallelism tolerance to 0.01mm via the digital Control unit.

All electrical components are of European quality supplied by, Telemecanique, Merlin Gerin and ABB.

Features

- Hydraulic / Mechanical ram, synchronised positive stop design, ram stroke controlled by precision mechanical nut depth stops built into each cylinder. Electronically controlled by Estun NC-E21 Programmable digital control assuring accurate repeatability.
- Parallelism is ensured by torsion bar that can be easily adjusted by clutch system.
- Estun NC-E21 programmable digital control stores up to 40 unique programs with 25 automatic progressive bending steps in each individual program, assuring production accuracy & repeatability every time.
- Estun NC-E21 programmable hardened ballscrew backgauge system, simply enter the desired measurement into the controller and press go, the backgauge then will move quickly into the position you have requested. The superior hardened ballscrew system eliminates any backlash that leadscrew type machines produce.
- Segmented heavy duty 86° offset top punch is segmented for return bend clearance, complete with European style quick release punch holder with an adjustable wedge clamping system for crowning.
- Intermediate clamp has safety key to stop punch dropping.
- Multi vee ('V') bottom die is made from one 4000mm solid die block design to handle heavy plate, safety edge vee ('V') is incorporated in bottom die block.
- Conveniently mounted control box on pendant for quick swivel and adjustments.
- Mono-block steel frame design, welded then machined to ensure minimal bed deflection under load
- Enclosed rear gate with micro safety switches complete with sliding rear door for easy access.
- European Style Intermediate clamping system, allowing operator to change position of tooling to suit multiple requirements on complex applications. This feature ensures minimum down time, more productivity and results in reduced cost per finished product.
- Sliding steel fabricated sheet supports enabling a wide range of material sizes to be aligned and supported at the correct required height. This feature is achieved with a "T" slot machined down the total length of the die bed, sheet supports are also adjustable vertically to assist

Product Brochure For S908G

- in supporting material with return bends already folded.
 - Adjustable sliding blocks control the machines beam to provide desirable open height distance to the (slow speed) mute bending point.
 - Operator adjustable locking knobs for quick adjustment, enables accurate repeatability and increased productivity.
 - Metal safety guarding surrounding the machine with rear sliding door fitted and micro switch ensuring operator safety.
 - Clear access panels placed at each end of machine allows the operator to clearly view tooling and work piece during bending operation. MetalMaster specially design gates to suit Australian safety requirements.
 - Hydraulic MPA pressure gauge mounted on right side of support frame with quick adjusting pressure control knob allowing operator to accurately set the pressure required for different material thickness, incorporating with hydraulic overload protection.
 - Welded steel fabricated synchronised torsion bar horizontally supporting main bending beam to provide consistent parallelism that also can be adjusted for taper correction.
 - The vertical supporting slides are treated to provide greater wear resistance and increased accuracy.
 - Reinforced side frames providing addition support strength to machine throat.
 - Includes safety control guarding system with light curtains fitted
 - Mild steel capacity is rated on hot rolled material with 250MPA
- Pre-Commissioning:
 1. Pressbrake is run & tested prior delivery
 2. Hydraulic oil is included with machine

Includes

- Operated by ESTUN NC- E21 control mounted on a swivel pendant for optimal ergonomics
- LED superior bright work lights provides clearer view to workpiece
- Sliding front sheet support arms
- Emergency stop buttons conveniently located on control panel and foot control
- Mobile dual operation foot control
- 86 Degree Top Punch with Segments (4x800, 1x365, 1x200, 1x100, 1x50, 1x40, 1x20, 1x15, 1x10)
- Top tooling tool intermediate holder system with wedge type adjustment
- Multi V bottom die block 95 x 95mm with a range of V's between 4mm~65mm
- Premium linear way side mount ballscrew backgauge with 520mm travel
- Metal constructed safety guarding surrounding machine with clear side viewing panels
- Integrated hydraulic system allowing rapid approach switching automatically to slow bend
- Includes safety control guarding system with light curtains fitted

Specific Features



Left View

Right View

Curtains In Use

NC Estun E21 Controller

NC Estun E21

Adjupstment Travel Control

Enclosed Rear Safety Guarding

Top-Bottom Tooling

Product Brochure For S908G



Intermediate Clamps



Adjustable and Sliding Front Sheet Supports

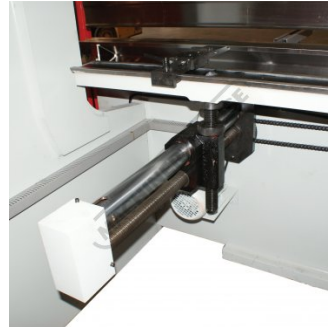

Ezy Set NC 89 Go To Back Gauge



Adjustable Pressure Control



Mobile Foot Control



Mobile Foot Control Top Buttons



Adjustable Top Tool Taper Wedge System



Adjustable Pressure Control

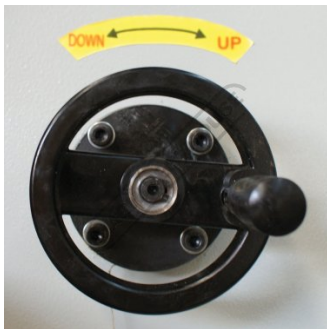

Fine Adjustment Beam Positioning



Fine Adjust Back Gauge



Synchronised Torsion Bar



Synchronised Torsion Bar

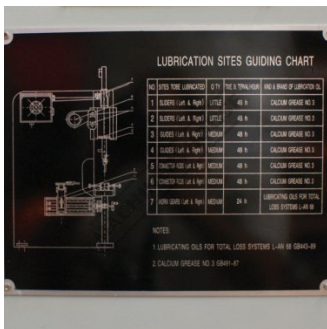

Lubrication Chart

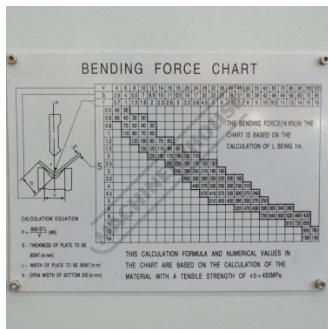

Tonnage Calculation Chart

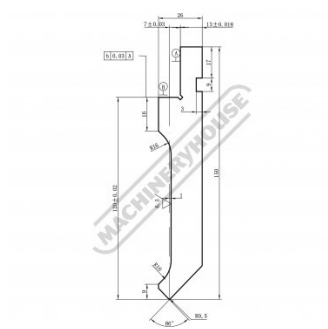

Segmented Top Punch

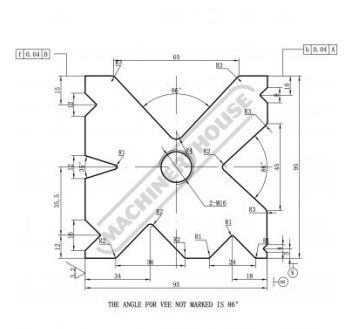

One Piece 4 Sided Die

Product Brochure For S908G



Shown with Optional Ball Transfer Tables

Recommended Accessories

S988

Quick Action Intermediate Clamps



S991S

86° Top Punch Pressbrake Tooling - Segmented



S991

86° Top Punch Pressbrake Tooling



S991F

86° Top Punch Pressbrake Tooling



S993A

95mm Die Block Pressbrake Tooling

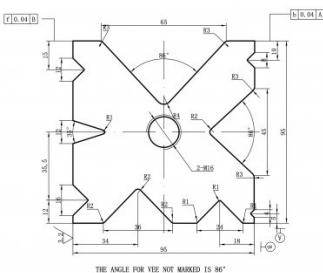

S990S

35° Top Punch Pressbrake Tooling - Segmented

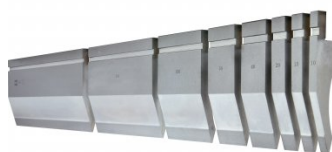

S990

35° Top Punch Pressbrake Tooling



S990F

35° Top Punch Pressbrake Tooling



Product Brochure For S908G

S997
15° Top Punch Pressbrake Tooling



S997A
60mm Die Block Pressbrake Tooling

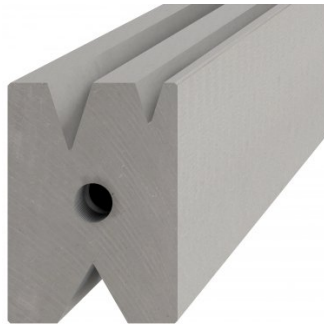

S997B
60mm Die Rail Pressbrake Tooling



Q200
Combination Set

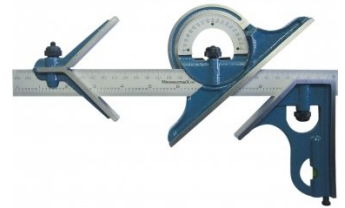

Q200A
Combination Set



Q201
Universal Bevel Protractor



Q2105
Digital Height Gauge



M970
Digital Angle Rule



M972
Digital Angle Rule



M974
Digital Angle Rule



M800
Rubber Mat - Anti-Fatigue



M805
Rubber Mat - Anti-Fatigue

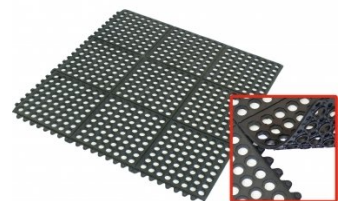

Product Brochure For S908G

O043
Rust & Corrosion Preventive



O042
General Purpose Lubricant & Corrosion Inhibitor



O044
Rust & Corrosion Preventive

