

## Product Brochure For S228

### Power Hammer - PHM-560MK2

1.2mm Mild Steel Capacity  
560mm Throat Depth



**Ex GST**  
**\$5,430.00**

**Inc GST**  
**\$6,244.50**

ORDER CODE:	S228
MODEL:	PHM-560MK2
Machine (Type):	Power Hammer
Mild Steel - Capacity (mm / Gauge):	1.2 / 18
Aluminium - Capacity (mm / Gauge):	1.6 / 16
Cubic feet per minute (CFM):	~
Tooling Height Adjustment (mm):	~
Tooling Shank Size (mm):	16
Throat Depth (mm):	560
Throat Height (mm):	395
Length of Stroke Adjustment (mm):	~
Radius Anvil Sizes (mm):	~
Speed - blows per minute (BPM):	0 - 960 (Variable)
Air Consumption (CFM):	~
Working Height (mm):	~
Air Pressure (psi):	~
Motor Power (kW / hp):	1.1 / 1.5
Voltage / Amperage (V / amp):	240 / 10
Machine Dimensions (LxWxH) (mm):	530 x 860 x 1790
Tooling Holder/Power Unit Dimensions (LxWxH) (mm):	~
Nett Weight (kg):	195



### Description

At last, there's an affordable solution for metal shaping. The PHM-560MK2 Metalmaster Electric Power Hammer was designed to have all the features of larger machines without the price tag. The ability to switch between rigid and non-rigid modes to suit your project makes this machine even more flexible. Only limited by your imagination the PHM-560MK2 can shrink, stretch, dome, edge turn, bead and form louvers, ideal for shaping sheet metal for cars, motorbikes & airplane panels. It has a 12mm thick steel fabricated upper frame and is supplied with an extensive range of CR12 hardened steel dies for shaping steel and nylon dies for forming softer metals like aluminium. It has variable speed via inverter control, with 0-960 strokes per minute and the capability of shaping up to 1.2mm thick sheet mild steel and up to 1.6mm thick sheet aluminium.

### Features

- Capacity - 1.2mm thick sheet mild steel
- Quick change tool holder
- 16mm square Shank Tooling
- Rigid & Spring Modes
- Variable speed via inverter control, 0 - 960 blows per minute
- 560mm throat depth capacity
- 395mm throat height capacity
- Foot pedal control with emergency stop
- Steel fabricated upper frame - 12mm thick plate
- Steel fabricated lower box section steel frame
- Drive shafts have bronze bushes & greasing points
- Adjustable heavy duty single arm length stop with 1 round roller & guide fence
- Safety magnetic power switch
- Steel dies made from CR12 steel & hardened
- Nylon dies made from durable nylon
- 1.1kW / 1.5hp, 240V motor

### Includes

- 1 x Straight Fence
- 1 x Contour Roller Guide for concave or convex shapes

- STEEL DIES

## Product Brochure For S228

- 1 x Set of Universal holders (14mm opening) for custom tooling (16mm square shank)
- 1 x Set of Thumbnail Shrinking Dies (16mm square shank)
- 1 x Set of Louvre Dies (16mm square shank)
- 3 x Sets of Beading Dies (1/4", 3/8", 1/2") (16mm square shank)
- 1 x Linear Stretching Die (16mm square shank)
- 1 x Flat Upper Hammer Die (16mm square shank)
- 1 x Set of Round Die Holders Ø20 x 20mm (16mm square shank)
- 1 x Set of 3.1" Doming Dies (Ø20 x 20mm Shank)
- 16 x Steel Lower Dies - 3/4", 7/8", 1", 1-1/8", 1-1/2", 1-7/8", 2", 3", 4", 5", 6" (1/16" radius edge), 6" radius (1/4" radius edge), 8", 14-1/2", 24", 36" Radius (Ø20 x 20mm Shank)
- NYLON DIES
- 1 x Flat Upper Hammer Die (Ø20 x 20mm Shank)
- 13 x Nylon Lower Dies - 3/4", 7/8", 1", 1-1/8", 1-1/2", 1-7/8", 4", 5", 6" (1/16" radius edge), 6" (1/4" radius edge), 8", 14-1/2", 24", 36" Radius (Ø20 x 20mm Shank)

### Optional Accessories

- Recommended Grease – (High Temperature Rated)
- Penrite Heavy Duty Bearing Grease 450GM – HDBG00045
- Nulon Earth Moving & Construction NLGI 2 Grease 450g – EMCG-C

### Specific Features



Quick Change Tooling



Full Die Set-Accessories



Die Holder Storage



Reinforced 12mm Frame

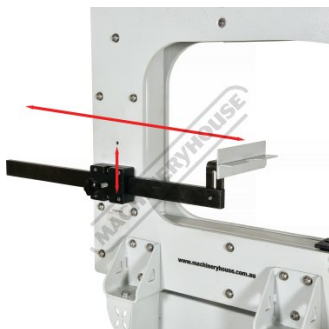

Stop Adjustable Depth-Position



Adjustable Depth Stop Height



Round Roller Guide



Die Height Adjustment

Product Brochure For S228



Switching Hammer Mode



Hand Wheel Top Adjusting Tooling



Top Die Wheel Adjustment



Setting-Locking Depth



Grease Points



Foot Control



Emergency Stop



Die Holders



Custom Die Holders



Shown Setup with Optional Custom Tooling



Adjusting Tools Included



Right View

Product Brochure For S228

**Recommended Accessories**

**S2290**  
Small Louvre Die Set - 16mm  
Square Shank



**S2292**  
EDGE TURNING DIE SET



**S2294**  
Small Thumbnail Die Set -  
16mm Square Shank



**S2295**  
Medium Thumbnail Die Set -  
16mm Square Shank



**S2296**  
Medium Nylon Thumbnail Die  
Set - 16mm Square Shank



**S2298**  
Power Hammer Full Tooling Set  
- 16mm Square Shank



**S2277**  
Pneumatic Planishing Hammer  
On Stand



**S223**  
Straight Steel T-Dolly Set Small  
- 5 Piece



Product Brochure For S228

**S2231**  
Straight Steel T-Dolly Set Large  
- 2 Piece



**S2232**  
Tapered Steel T-Dolly Set - 3  
Piece

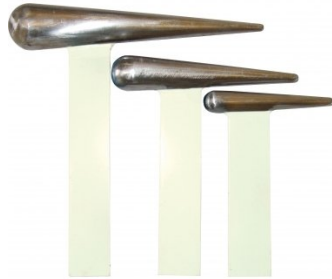

**S2233**  
Curved Steel Dolly Set - 3 Piece



**S2234**  
Mushroom Steel Dome Dolly Set  
- 2 Piece

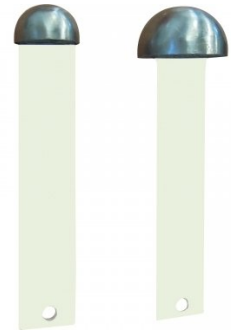

**S2235**  
Mushroom Steel Dome Dolly Set  
- 2 Piece



**S2236**  
Oval Steel Dolly



**S2237**  
Bowl Steel Dome Dolly



**S2239**  
Dolly Stand Holder



**S2238**  
Steel Dolly Stand



**S214**  
Rectangle Leather Bag - Steel  
Shot Filled



**S212**  
Rectangle Leather Bags - Sand  
Filled



**S210**  
Round Leather Bags - Sand  
Filled



Product Brochure For S228

---

H885

Auto Panel Restoration Kit - DIY



H886

Auto Panel Restoration Kit - Professional



H887

Auto Panel Restoration Kit - Master

