

Product Brochure For R028

Tilting Rotary Table - TRT-12

Ø320mm



ORDER CODE:	R028
MODEL:	TRT-12
Size (mm):	320
A (mm):	380
B (mm):	322
C (mm):	252
D (mm):	Ø320
E (mm):	16
F (mm):	241
H (mm):	175
L (mm):	255
M (MT):	MT4
P (mm):	40
d (lowercase) (mm):	Ø40
h (lowercase) (mm):	10
T-Slot Size (mm):	14
Worm Ratio:	90:1

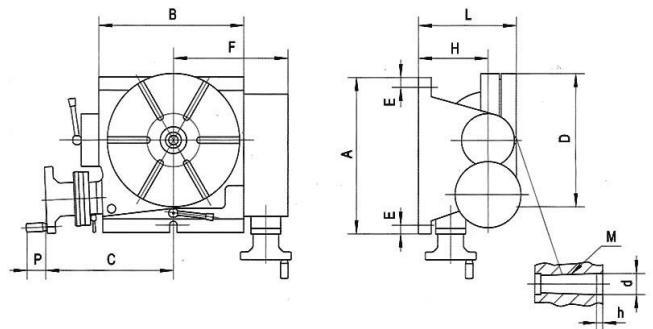

Features

- An accurately designed rotary table for milling, boring and other machining operations
- The table allows for indexing, and other operations to be carried out rapidly with precision
- Low profile design minimises machine capacity losses without sacrificing work load capacity
- Tilting range from 0 - 90 degrees from the horizontal to vertical position and locked
- T-slots are machine to accept standard tee nuts
- One spindle rotation of the handle is equal to 3 degrees
- Accuracy of the tilting operation is 2 minutes
- 10 second vernier scale on table
- Table dial graduations 1 minute
- Worm ratio is 90:1
- Includes dividing plates

Optional Accessories

- Optional tailstock to suit CODE: R015

Product Brochure For R028

Specific Features

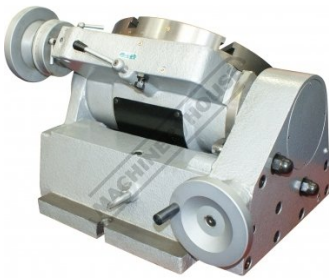

Rear View

Recommended Accessories

R015
Vertex Tailstock

C086
Clamp Kit Tee Nuts

C0965
Clamp Kit 58 piece - Workshop Series

