

Product Brochure For R012A

## Vertex Rotary Table - HV-14

Ø355mm



Back In Stock Soon

Ex GST                      Inc GST  
\$1,696.00                \$1,950.40

ORDER CODE:	R012A
MODEL:	HV-14
Size (mm):	355
A1 (mm):	130
D (mm):	350
H (mm):	140
H1 (mm):	230
A (mm):	450
B (mm):	380
e (mm):	16
g (mm):	18
Number of T-Slots (No.):	6
T-Slot Size (mm):	16
Taper In Centre (MT):	4MT
Nett Weight (kg):	95



### Description

Manufactured in Taiwan

The Vertex Rotary Table has been designed to be used where a precision work positioning device is required. It allows the operator to mill or drill components at exact intervals around a fixed axis. Additional indexing plates can be fitted to allow the Vertex Rotary Table to be used as a Dividing Head. The Vertex Rotary Table can be used in both the horizontal or vertical plane.

### Features

- The Vertex Rotary Table is manufactured from high-density Meehanite cast iron with ground surface areas on the table and body to ensure smooth rotation
- Critical wear parts are hand finished for ultra precision
- All tables are tested for accuracy using 'Heidenhain' electronic equipment to ensure continuing quality
- Worm is hardened and precision ground, with a ratio of 90:1
- Table is graduated to a full 360° so one turn of the handle moves the table 4°
- The collar on the handle is graduated with a vernier scale, readings down to 10 seconds are possible

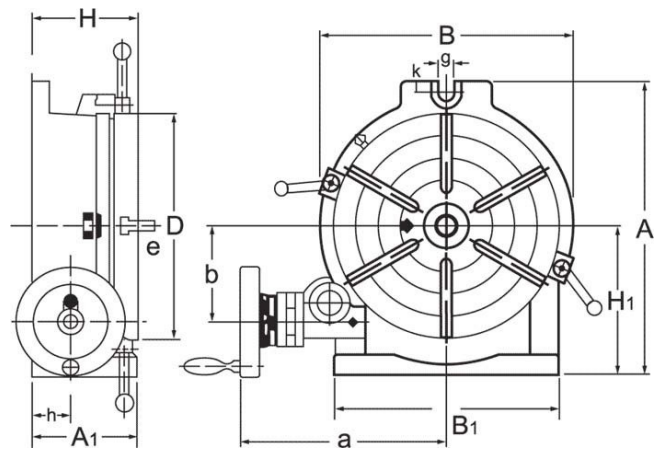

Product Brochure For R012A

---

**Specific Features**



Vertical View

**Recommended Accessories**

R020  
Vertex Dividing Plate

C281  
3 Jaw Self Centring Lathe  
Chuck

C087  
Clamp Kit Tee Nuts

C096A  
Clamp Kit 58 piece - Industrial  
Series

