

Product Brochure For R005

Vertex Rotary Table - HV-4

Ø110mm



Description

Manufactured in Taiwan

The Vertex Rotary Table has been designed to be used where a precision work positioning device is required. It allows the operator to mill or drill components at exact intervals around a fixed axis. Additional indexing plates can be fitted to allow the Vertex Rotary Table to be used as a Dividing Head. The Vertex Rotary Table can be used in both the horizontal or vertical plane.

Features

- The Vertex Rotary Table is manufactured from high-density Meehanite cast iron with ground surface areas on the table and body to ensure smooth rotation
- Critical wear parts are hand finished for ultra precision
- All tables are tested for accuracy using 'Heidenhain' electronic equipment to ensure continuing quality
- Worm is hardened and precision ground, with a ratio of 90:1
- Table is graduated to a full 360° so one turn of the handle moves the table 4°
- The collar on the handle is graduated with a vernier scale, readings down to 10 seconds are possible

ORDER CODE:	R005
MODEL:	HV-4
Size (mm):	110
A1 (mm):	70
D (mm):	110
H (mm):	80
H1 (mm):	85
A (mm):	145
B (mm):	115
e (mm):	11
g (mm):	12
Number of T-Slots (No.):	3
T-Slot Size (mm):	11
Taper In Centre (MT):	2MT
Nett Weight (kg):	7.5

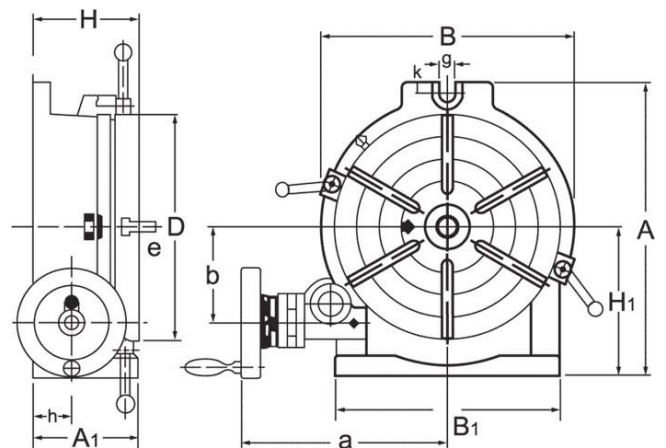

Product Brochure For R005

Specific Features



Vertical View

Recommended Accessories

R013
Vertex Tailstock

R016
Vertex Dividing Plate

C085
Clamp Kit Tee Nuts

C0948
Mini Clamp Kit 10 piece -
Workshop Series



C0945
Clamp Kit 58 piece - Workshop
Series

