

Product Brochure For Q515

## Centering Dial Indicator - 34-515

0 - 3mm

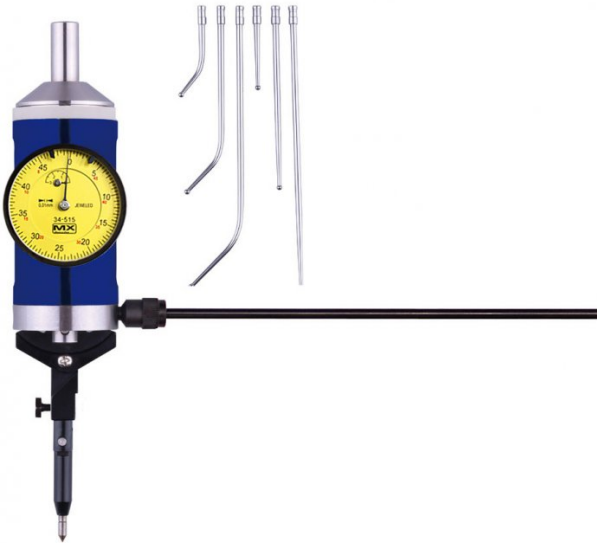

**On Sale**

|                 |                 |
|-----------------|-----------------|
| <b>Ex GST</b>   | <b>Inc GST</b>  |
| <b>\$244.00</b> | <b>\$280.60</b> |
| <b>\$194.78</b> | <b>\$224.00</b> |

|                           |              |
|---------------------------|--------------|
| ORDER CODE:               | Q515         |
| Range (mm):               | 0 - 3mm      |
| Graduations (mm):         | 0.01mm       |
| Straight Stylus (mm):     | 45, 100, 154 |
| Curved Stylus (mm):       | 45, 100, 154 |
| Swivel Point Stylus (mm): | 52.5         |
| Stylus Diameter (mm):     | 3            |
| Mount (mm):               | 10           |



### Description

Used to locate a work piece center quickly and accurately whilst the indicator faces the operator at all times by way of a restraining arm.

### Features

- Quick and accurate centering internal & external
- Operates at any angle from horizontal to vertical
- The dial indicator remains stationary while rotating the spindle manually.
- The set includes 7 stylus probes and a restraining arm.
- Packed in wooden box

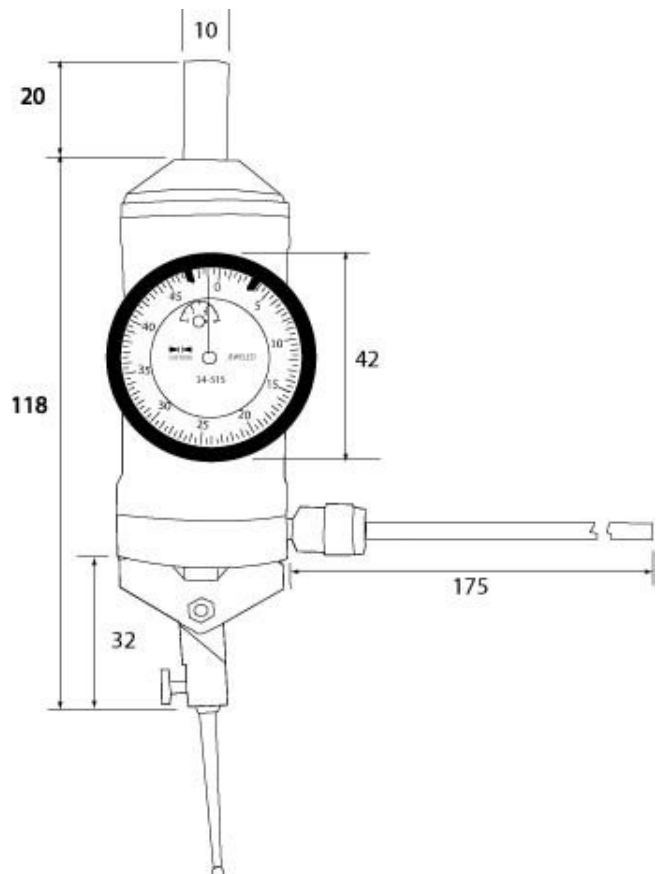

Product Brochure For Q515

---

**Specific Features**



Jeweled Metric Dial



Stylus Shown Attached



Stylus



Centre Dial



Wooden Box