

Product Brochure For Q507

Pocket Dial Thickness Gauge - 34-507

0-10mm

ORDER CODE:	Q507
Range (mm):	0 - 10
Graduation (mm):	0.01

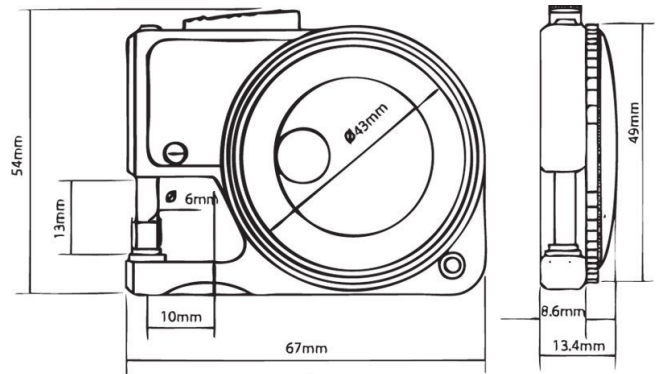

Features

- The dial thickness gauges are used to measure the thickness of paper, leather, rubber, fabric, metal plate, glass and plastic plate etc
- Standard steel contact point and anvil Ø10mm Diameter
- Compact design
- Ideally suited for quick inspection

Product Brochure For Q507

Recommended Accessories

Q2165

Ø10mm Flat Contact for Dial Indicators



Q2167

Contact Point for Dial Indicators

