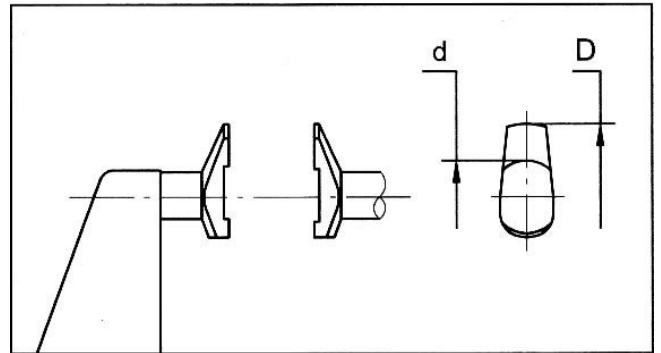

## Product Brochure For Q5014

**Micrometers - Jaw Type - 45-5014**

75-100mm

ORDER CODE:	Q5014
Range (mm):	75 - 100
Accuracy (mm):	0.005
d (lowercase) (mm):	Ø8
D (Radius) (mm):	10

**Description**

The Measumax Jaw Type Micrometer is specially designed for measuring gear tooth dimensions and hard to reach recesses and grooves

**Features**

- Non Rotating spindle
- Ratchet thimble
- Painted frame
- Resolution 0.01mm

Product Brochure For Q5014

---

**Specific Features**



Anvils

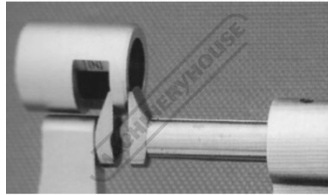

Shown Measuring

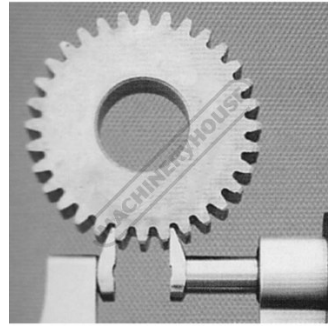

Shown Measuring