

Product Brochure For Q5012

Micrometers - Jaw Type - 45-5012

25-50mm

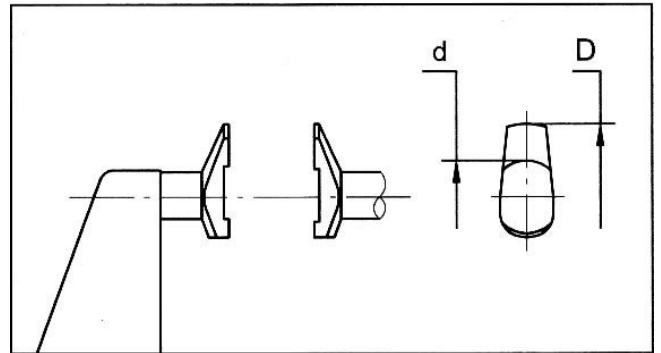

ORDER CODE:	Q5012
Range (mm):	25 - 50
Accuracy (mm):	0.004
d (lowercase) (mm):	∅8
D (Radius) (mm):	10

**Description**

The Measumax Jaw Type Micrometer is specially designed for measuring gear tooth dimensions and hard to reach recesses and grooves

Features

- Non Rotating spindle
- Ratchet thimble
- Painted frame
- Resolution 0.01mm

Product Brochure For Q5012

Specific Features



Anvils

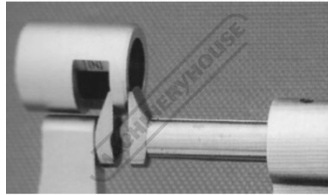

Shown Measuring

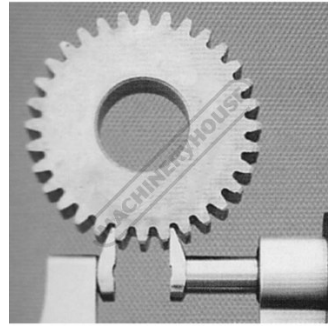

Shown Measuring