

Product Brochure For Q501

Micrometers - Jaw Type - 45-501

0-25mm

ORDER CODE:	Q501
Range (mm):	0 - 25
Accuracy (mm):	0.004
d (lowercase) (mm):	Ø8
D (Radius) (mm):	10

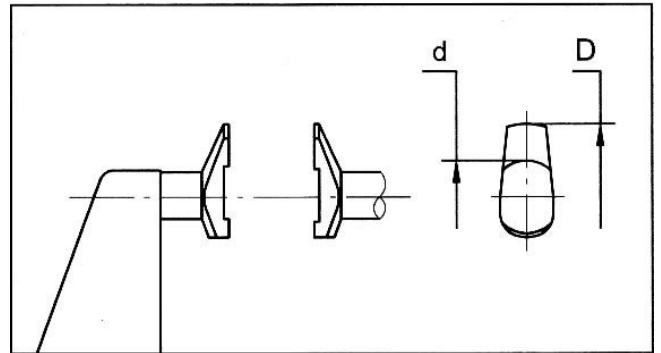

Description

The Measumax Jaw Type Micrometer is specially designed for measuring gear tooth dimensions and hard to reach recesses and grooves

Features

- Non Rotating spindle
- Ratchet thimble
- Painted frame
- Resolution 0.01mm

Product Brochure For Q501

Specific Features



Anvils

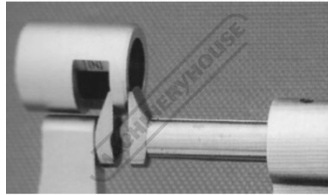

Shown Measuring

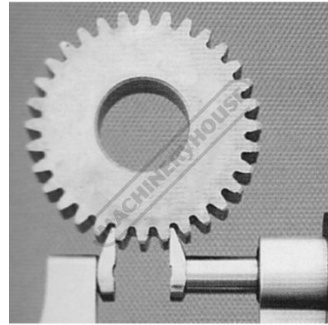

Shown Measuring