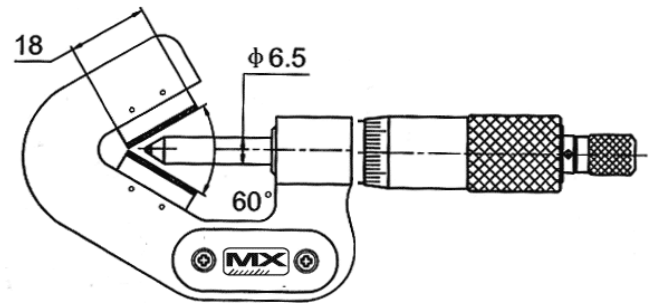

Product Brochure For Q495

V-Anvil Micrometer - 11-495

2.3-25mm

ORDER CODE:	Q495
MODEL:	11-495
Range (mm):	2.3 - 25
Accuracy (mm):	0.004

**Description**

Measumax V-Anvil micrometers are suitable for measuring cylinders with odd number flutes such as taps, reamers and 3 flute end mills.

Features

- Ratchet Thimble
- Painted frame
- Positive locking clamp
- Resolution: 0.01mm