

Product Brochure For Q2205

Digital Indicator - 34-2205

12.5mm / 0.5"



Features

- Manual power On/Off
- Zero setting at any position
- Metric/Imperial system conversion at any position
- With data output interface (cable 40-4061)
- Max speed 1.5m/sec
- Supplied with Lugged Back

Includes

- Includes CR2032 battery

On Sale

Ex GST	Inc GST
\$148.00	\$170.20
\$116.52	\$134.00

ORDER CODE:	Q2205
Range (mm / inch):	12.5mm / 0.5"
Resolution:	0.01mm / 0.0005"
Accuracy:	0.02
Diameter:	55
A:	8

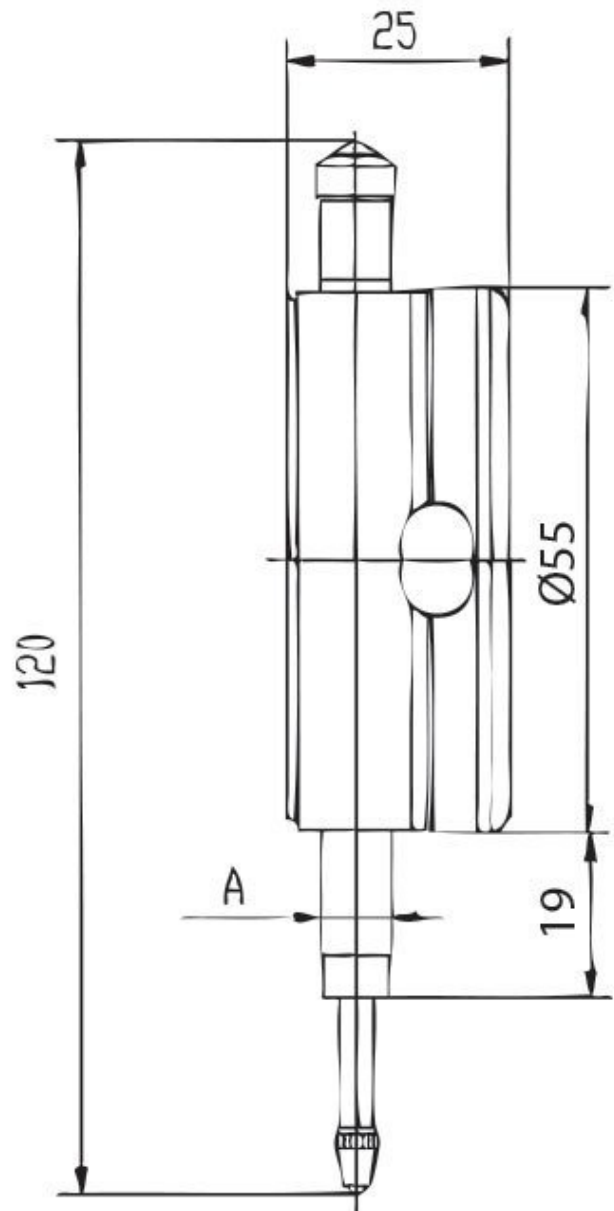

Product Brochure For Q2205

Recommended Accessories

Q2165
Ø10mm Flat Contact for Dial Indicators



Q2167
Contact Point for Dial Indicators



M050
Magnetic Base - Standard



M051
Magnetic Base - Deluxe - One Lock



Q430
Magnetic Base - Small



Q435
Magnetic Base - Large



Q4351
Magnetic Base - Large



Q436
Magnetic Base - One Lock (Large)

