

Product Brochure For Q2175

## Dial Test Indicator - Metric - 34-2175

Ø2mm Carbide Ball End

0 - 0.8mm



ORDER CODE:	Q2175
Range:	0 - 0.8mm
Graduations:	0.01mm
A (mm):	26
B (mm):	18.5
B1 (mm):	8.9mm
C (mm):	16.5
D (mm):	Ø37.5
d (mm):	6 / 8
E (mm):	42.7
F (mm):	38.7
G (mm):	48
H (mm):	~
I (mm):	13
J:	~
K (mm):	72.8
L (mm):	46.4
L1 (mm):	42.4
Ø (mm):	2

Product Brochure For Q2175

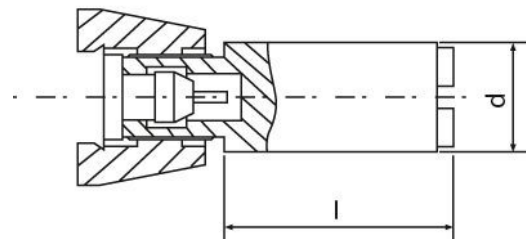
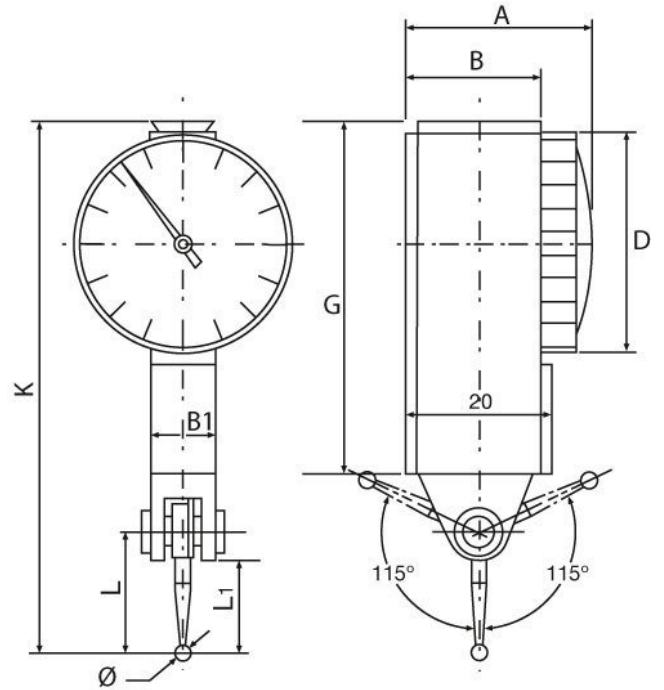

**Features**

- High quality brass main bodies, high resistance to magnetism
- Jewelled, vibration proof, durable steel ball
- Metal bezel
- Pivot ball bearing
- Three dovetails



Product Brochure For Q2175

---

Q4351  
Magnetic Base - Large



Q436  
Magnetic Base - One Lock  
(Large)

