

Product Brochure For Q216

Micron Dial Indicator - 34-216

0-12.7mm



ORDER CODE:	Q216
Range (mm):	0 - 12.7
Graduations (mm):	0.002
A (mm):	42.5
B (mm):	21
C (mm):	8
D (mm):	57
E (mm):	19
F (mm):	17
G (mm):	6.35
H (mm):	8

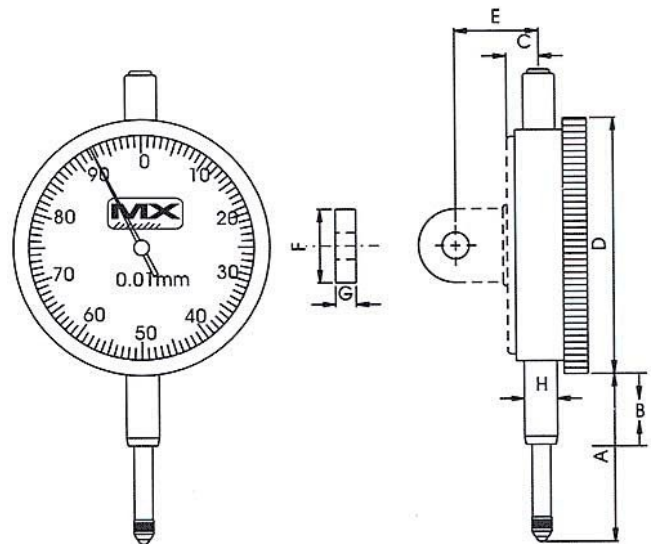

Features

- Smooth 10 jewel movement
- In-out tolerance marker
- Flat glass - metal bezel
- Protected top spindle extension
- Flat back and back lug
- Peach shape body
- Dial reads 0.002mm (2µm)
- Supplied in foam lined plastic case with test reports

Product Brochure For Q216

Recommended Accessories

Q2165
Ø10mm Flat Contact for Dial Indicators



Q2167
Contact Point for Dial Indicators



M050
Magnetic Base - Standard



M051
Magnetic Base - Deluxe - One Lock



Q430
Magnetic Base - Small



Q435
Magnetic Base - Large



Q4351
Magnetic Base - Large



Q436
Magnetic Base - One Lock (Large)

