

Product Brochure For Q210

Digital Height Gauge - 36-210

0 - 300mm

Dual Column Type



ORDER CODE:	Q210
Range (mm / inch):	0 - 300mm
Type:	Digital
Resolution (mm / inch):	0.01mm / 0.001"
Accuracy (mm):	±0.04

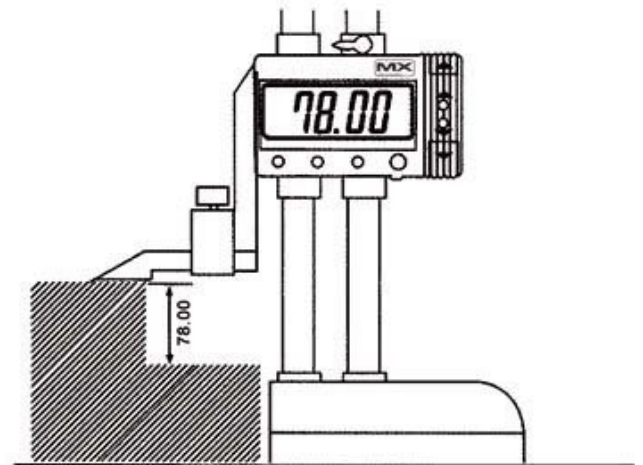
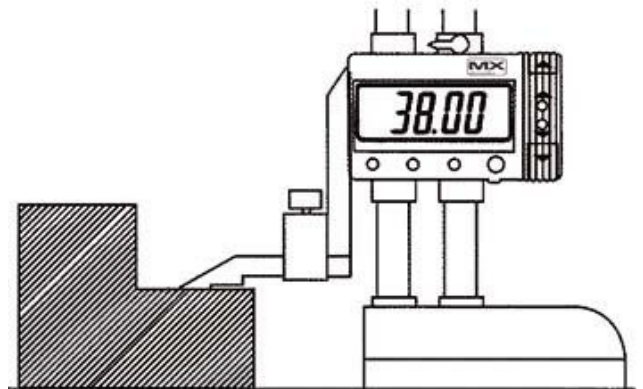

Features

- Dual column for precision accuracy
- Large display screen
- Metric/Imperial conversion
- Manual ON/OFF
- Absolute and comparison measurements
- Zero at any position
- Hold and tolerance functions
- Vertical feed wheel for easy adjustment

Product Brochure For Q210

Specific Features



Close Up

Recommended Accessories

M710

Cast Iron Surface Plate

Q810

Granite Surface Plate

