

Product Brochure For Q1996

## Vernier Calipers - 33-1996

2000mm/78"

Large Mono Block

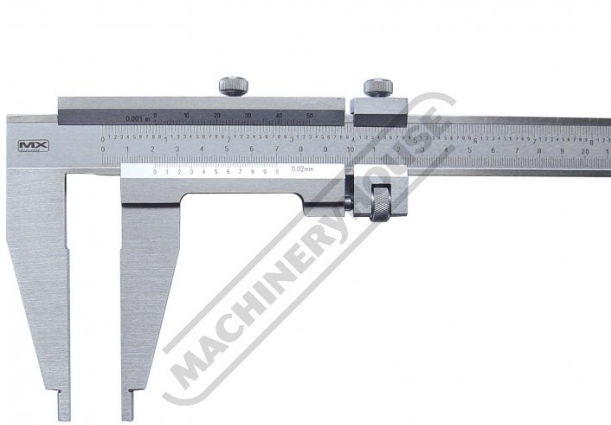

ORDER CODE:	Q1996
Range (mm / inch):	2000mm / 78"
Graduations (mm / inch):	0.02mm / 0.001"
Accuracy (mm):	±0.14
J (mm):	200
B (mm):	20
C (mm):	20
D (mm):	52

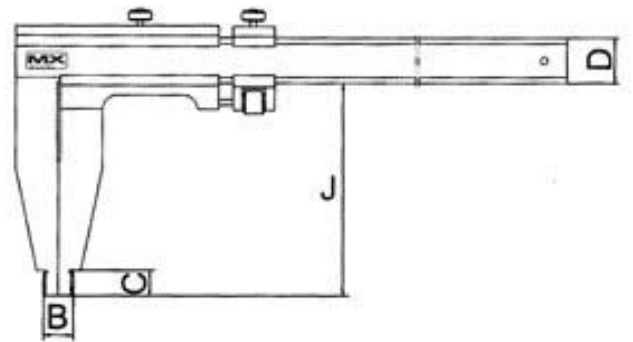

### Features

- Precision vernier calipers with stainless steel body and slides
- Clear graduations - Metric/Imperial graduations
- Mono-block design
- Supplied in wooden case
- Instrument are manufactured to ISO 10012:2003
- An ISO9001:2000 Company

## Product Brochure For Q1996

---

### Specific Features



### Metric and Imperial Graduations