

Product Brochure For Q1995

Vernier Calipers - 33-1995

1500mm/60"

Large Mono Block

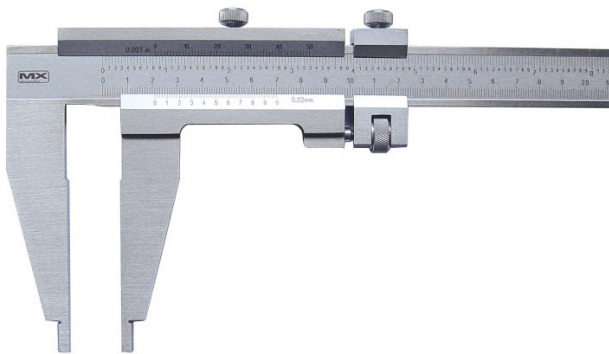

ORDER CODE:	Q1995
Range (mm / inch):	1500mm / 60"
Graduations (mm / inch):	0.02mm / 0.001"
Accuracy (mm):	±0.08
J (mm):	200
B (mm):	20
C (mm):	20
D (mm):	40

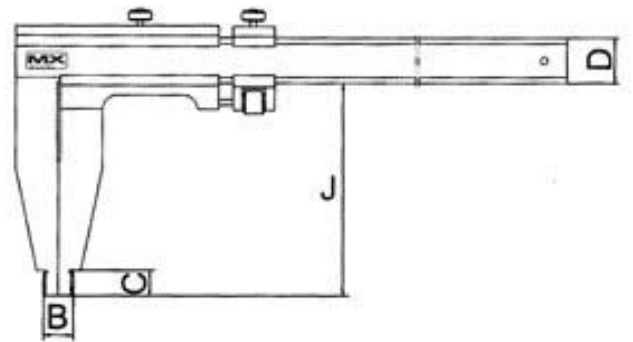

Features

- Precision vernier calipers with stainless steel body and slides
- Clear graduations - Metric/Imperial graduations
- Mono-block design
- Supplied in wooden case
- Instrument are manufactured to ISO 10012:2003
- An ISO9001:2000 Company

Product Brochure For Q1995

Specific Features



Metric and Imperial Graduations