

Product Brochure For Q198

Vernier Calipers - 33-198

600mm/24"

Large Mono Block

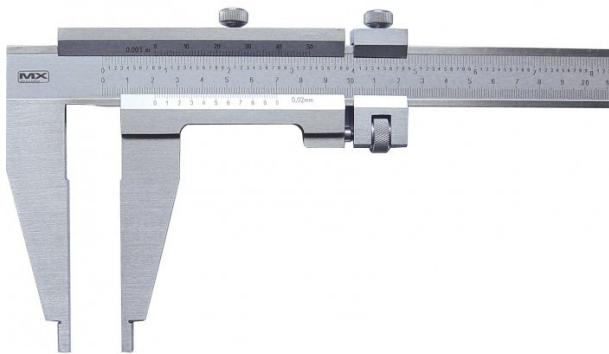

ORDER CODE:	Q198
Range (mm / inch):	600mm / 24"
Graduations (mm / inch):	0.02mm / 0.001"
Accuracy (mm):	±0.05
J (mm):	100
B (mm):	10
C (mm):	12
D (mm):	25

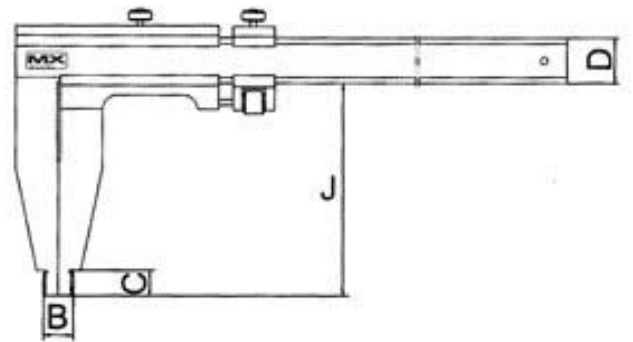

Features

- Precision vernier calipers with stainless steel body and slides
- Clear graduations - Metric/Imperial graduations
- Mono-block design
- Supplied in wooden case
- Instrument are manufactured to ISO 10012:2003
- An ISO9001:2000 Company

Product Brochure For Q198

Specific Features

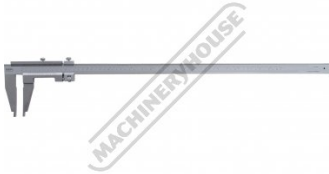

Full View



Metric and Imperial Graduations