

Product Brochure For Q146

# Depth Micrometer - 22-146

0-100mm

Metric

Ex GST  
**\$306.00**

Inc GST  
**\$351.90**



ORDER CODE:	Q146
Range (mm / inch):	0 - 100mm
Graduation (mm):	0.01
Accuracy (mm / inch):	±0.005mm
A (mm / inch):	100mm
Rods (No.):	4

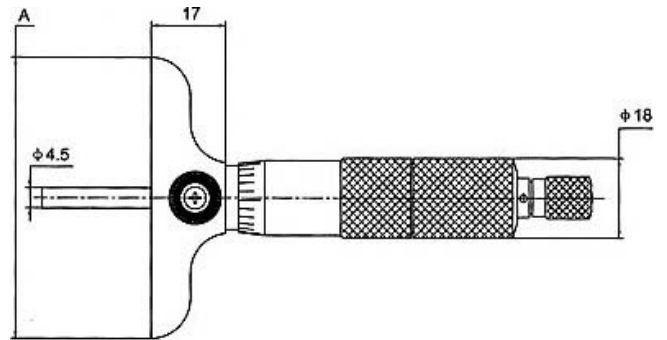

## Description

High accuracy interchangeable rods with hardened and micro lapped anvils, provide a wide measuring range

## Features

- High accuracy interchangeable rods with hardened and micro lapped flat anvils, provide a wide measuring range
- The interchangeable rods are held securely under the top ratchet section and have individual adjustment for resetting if required
- The base is hardened, ground and lapped for accuracy
- Ratchet stop for exact repetitive readings
- Positive locking clamp
- Resolution: Metric 0.01mm

Product Brochure For Q146

---

**Specific Features**



Graduations



Measuring Example



Figure 1



Figure 2



Figure 3