

Product Brochure For Q1291

Digital Universal Micrometer - 10-1291

25-50mm/1-2"

Includes 7 Anvils

ORDER CODE:	Q1291
Range (mm / inch):	25 - 50mm / 1 - 2"
Accuracy (mm):	0.002
C (mm):	38
L (mm):	67

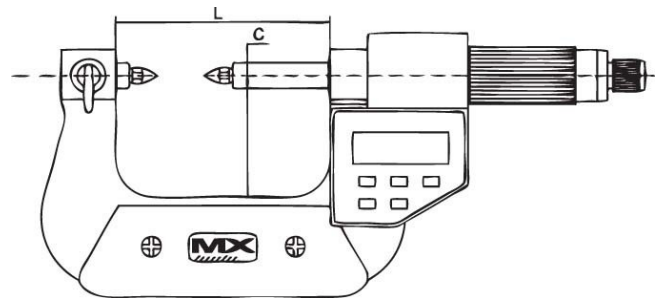

Description

Measumax Digital Universal micrometer features, clear easy to read numbers on a large display. Measurements can be made to 3 decimal places with quick, error free readings.

7 pairs of interchangeable anvils supplied with each unit.

Features

- Heat insulated baked enamel frame
- Resolution 0.001mm/0.0005"
- Protection level IP54, Metric/Inch conversion
- RS232 SPC data transfer (Cable 40-400)
- Ratchet stop
- Carbide tipped anvils, flatness 0.0008mm
- Criterion: DIN863/1, DIN40050/IEC529

Product Brochure For Q1291

ANVIL SPECIFICATIONS

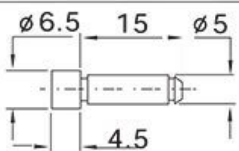
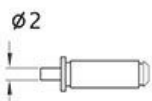
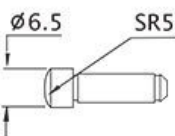
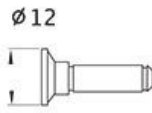
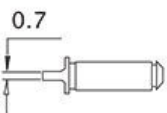
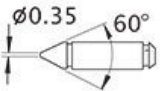
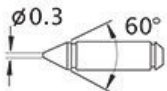
Anvils	Type	Anvils	Type
2 x Flat		2 x Spline	
2 x Spherical		2 x Disk	
2 x Blade		2 x Knife Edge	
2 x Point			

Specific Features



Complete with Case

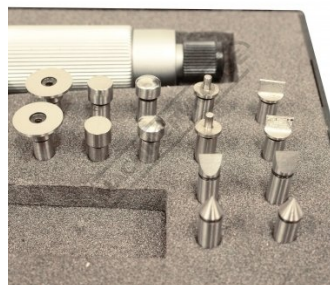

Anvil Set



Shown In Use with Blade Anvil



Shown In Use with Spline Anvil

Product Brochure For Q1291



Shown In Use with Disc Anvil



Shown In Use with Disc Anvil