

Product Brochure For Q124

Digital Outside Micrometer - 10-124

0-25mm / 0-1"



Back In Stock Soon

Ex GST
\$148.00

Inc GST
\$170.20

ORDER CODE:	Q124
Range (mm / inch):	0 - 25mm / 0 - 1"
Accuracy (mm):	±0.002
C (mm):	23
L (mm):	32
Protection Rating:	~
Direct RS-232 output (Yes / No):	No

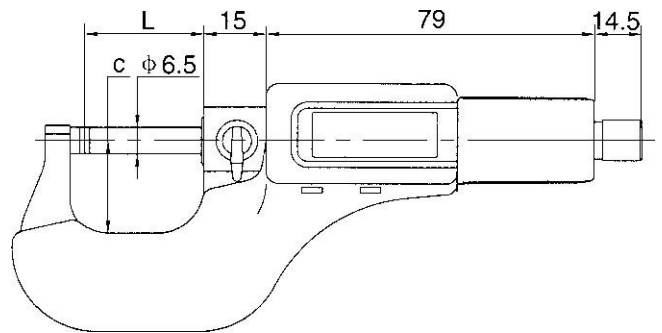

Description

Quick, accurate and easy to use, at an economical price.

Features

- Large LCD for easy reading
- Metric-imperial conversion and zero setting keys
- Friction thimble for easy one hand use
- Painted frame. Carbide measuring faces
- Resolution: 0.001mm/0.0005"

Includes

- Includes CR2032 battery
- Ball point adaptor for use with round pipe or tubes (wall thickness)

Product Brochure For Q124

Specific Features



Shown with Ball Point Adaptor

Recommended Accessories

Q675

Micrometer Stand

