

Product Brochure For P156

100T Hydraulic & Pneumatic Press - HPM-100P

Robotic Welded Steel Frame Construction

Includes Adjustable Sliding Cylinder Ram, Pressure Gauge & Bending Vee Blocks

Back In Stock Soon

Ex GST
\$7,186.00

Inc GST
\$8,263.90



ORDER CODE:	P156
MODEL:	HPM-100P
Pressing Capacity (Tonne):	100
Hydraulic Ram Operation (Type):	Hydraulic & Pneumatic
Sliding Ram (left-right) (Yes / No):	Yes
Width Between Front Posts (mm):	786
Width Between Side Posts (mm):	265
Table Top Opening - (Front to Back) (mm):	230
Ram To Table (Max.) (mm):	993
Cylinder Stroke (mm):	300
Ram Diameter (mm):	Ø100
Piston Diameter (mm):	~
Minimum Air Flow Rate required (L/Min):	200
Motor Power (kW / hp):	~
Voltage (V):	~
Floor Space (W x D x H) (mm):	1400 x 1000 x 1880
Nett Weight (kg):	658



Description

The Metalmaster HPM-100P 100 tonne press has a variety of uses, ideal for removing and installing bushes, ball joints, bearings, gears, pulleys etc. The HPM-100P is pneumatically or hand operated for easy use and has the added feature of a sliding head which can be moved to the side allowing for those offset pressing jobs.

This 100 tonne press has a fully robotic welded frame for the highest quality, accuracy, and extra rigidity. The hydraulics are assembled in a temperature controlled clean room along with being individually factory tested prior to shipping for maximum reliability & quality. The press is supplied with a pressure gauge, two heavy duty pressing plates, and is fitted with a pneumatic foot pedal, making it ideal for mechanics, farmers or the serious home workshop.

Features

- Ideal for removing and installing - Bushing, Ball-joints, Bearings, Gears, Pulleys, etc
- Pneumatic or hand operation
- Heavy duty steel construction with robotic fully welded frame
- Adjustable sliding head up to 250mm travel between the vertical post
- Metric / imperial pressure gauge included
- Table height adjustment via a hand operated winch
- NOTE: Minimum Air Flow Rate required is 200 liters/minute

Includes

- Heavy duty vee blocks

Product Brochure For P156

Specific Features



Ram

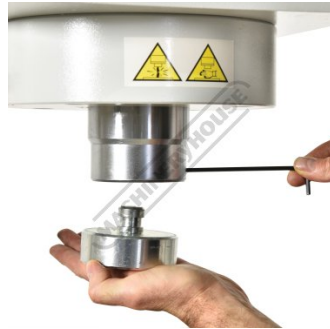

Removable ram cap



Metric imperial pressure gauge



Enclosed hydraulic unit



Hydraulic Valve



Manual Pneumatic Hydraulic Adjustment



Pneumatic Foot Pedal



Robot Welded Frame



Table Winch Height Adjustment



Heavy Duty Table Winch Points



Horizontal Sliding Ram Handle



Horizontal Sliding Ram



Dual Purpose Pressing Plates



Left View

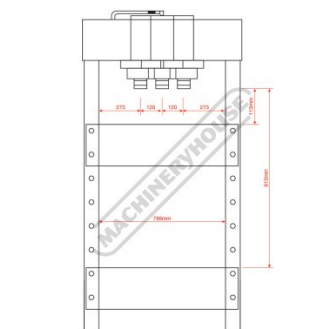

Dimensions

Product Brochure For P156

Recommended Accessories

P1407
Hydraulic Press Guard



P030
Bush Driver Set - 17 piece



P031
Bearing Race & Seal Driver Set - 10 piece



P1401
Steel Press Pin Driver Set - 11 piece

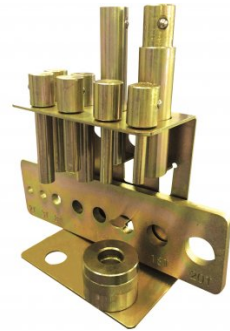

P455
Pressbrake Attachment - Suits Hydraulic Presses

