

Product Brochure For N014

## Rivet Nut Inserts - M4 x 0.7mm

Aluminium  
Qty 50 In Pack

Ex GST  
\$12.00

Inc GST  
\$13.80



ORDER CODE:	N014
MODEL:	-
Type:	Rivet Nut Inserts
Nut Insert Material (Type):	Aluminium
Quantity in Pack:	50
Rivet Nut Inserts Range (Metric):	-
Blind Rivets (mm):	-
Thread Size (T) (Metric):	M4 x 0.7
Thread Length (TL) (Metric):	-
Length (L) (mm):	10.5
Head Height (HH) (mm):	0.9
Head Diameter (HD) (mm):	9
Diameter (D) (mm):	5.9
Hole Size (HS) (mm):	6
Grip Range (GR) (mm):	0.25 - 2.50
Torque to Turn (Kgf.cm):	40



### Description

Suits ATR-10RN Air Operated or RNB40 Twin Handle Nut Riveters

### Features

- Aluminium inserts
- Fast & easy installation from one side
- Adds a threaded nut to thin sheet metal
- Knurled section under nut head for anti-rotation
- Easy to install
- \*\* NOTE: When used with RNB40 Nut Riveter, the M4 Nut Rivet Mandrel and Adaptor is required, sold separately (Order Code: N0022)

### Includes

- 50 x Rivet Nut Inserts - M4 x 0.7mm

## NUT INSERT

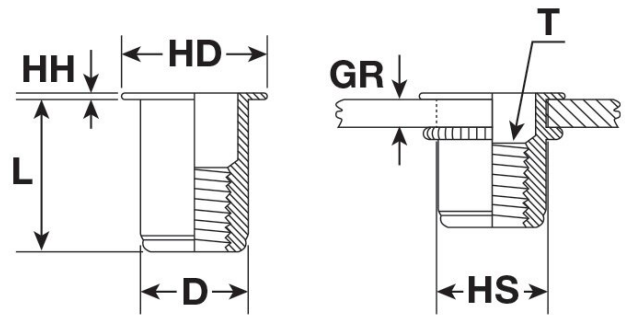

UNINSTALLED

INSTALLED

## Product Brochure For N014

### Specific Features



Packaging Front



Packaging Back

### Recommended Accessories

**N001**  
Nut & Blind Riveter Set - 130  
Piece



**N0022**  
NUT RIVET MANDREL &  
ADAPTOR



**N006**  
Rivet Nut Inserts - M6 x 1.0mm



**N008**  
Rivet Nut Inserts - M8 x 1.25mm



**N010**  
Rivet Nut Inserts - M10 x 1.5mm



**N015**  
Rivet Nut Inserts - M5 x 0.8mm



**N016**  
Rivet Nut Inserts - M6 x 1.0mm



**N018**  
Rivet Nut Inserts - M8 x 1.25mm



## Product Brochure For N014

---

N020

Rivet Nut Inserts - M10 x 1.5mm

