

Product Brochure For M5182

## Face Mill 45° - Super High-Rake - F45SE12-D125

Ø125mm

Insert tip not included



|                              |              |
|------------------------------|--------------|
| ORDER CODE:                  | M5182        |
| MODEL:                       | F45SE12-D125 |
| Cutter Approach Angle (deg): | 45°          |
| D (mm):                      | 125          |
| D1 (mm):                     | 114          |
| H (mm):                      | 60           |
| d (lowercase):               | 40mm         |
| Drawbar Thread:              | ~            |
| Number of Inserts (No.):     | 8            |
| Replacement Insert Tips:     | (L065)       |
| Nett Weight (kg):            | 1.85         |

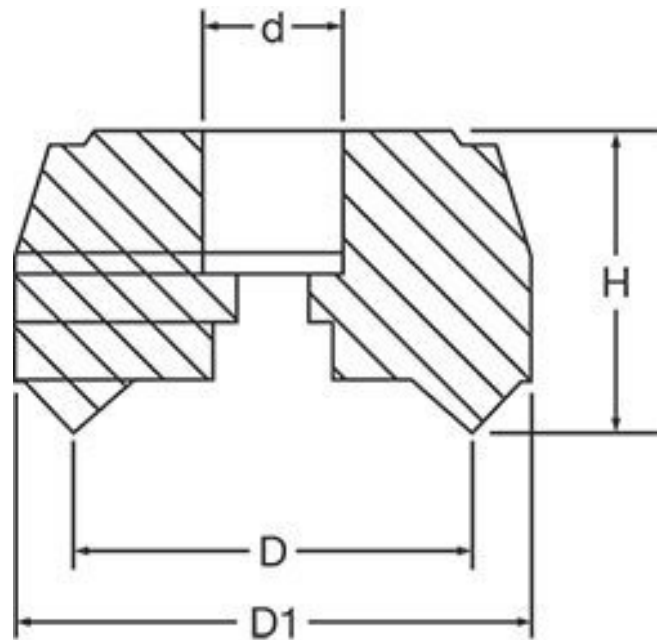

### Description

SUPER HIGH-RAKE FACE MILL - 125mm x 45°  
Use carbide inserts (ISO) SEKT1204 (L065)  
NOTE: Carbide Inserts not included

### Features

- Suitable for low horsepower machines where rapid metal removal is required.
- Suitable for steel, cast iron and non-ferrous metals
- Positive rake

### Includes

- Lock key for insert

Product Brochure For M5182

---

**Recommended Accessories**

L065  
KYOCERA Carbide Inserts -  
Milling



ML090  
Cutter Part - Screw



L538  
Key to Suit Tool Holder



M545  
Face Mill Arbor



M555  
Face Mill Arbor



T162  
BT40-FMB40-60 Face Mill Arbor

