

Product Brochure For M518

Face Mill 45° - Super High-Rake - F45SE12-D100

Ø100mm

Insert tip not included

On Sale

| Ex GST | Inc GST |
|---------------------|---------------------|
| \$258.00 | \$296.70 |
| \$205.22 | \$236.00 |



| | |
|------------------------------|--------------|
| ORDER CODE: | M518 |
| MODEL: | F45SE12-D100 |
| Cutter Approach Angle (deg): | 45° |
| D (mm): | 100 |
| D1 (mm): | 114 |
| H (mm): | 50 |
| d (lowercase): | 32mm |
| Drawbar Thread: | - |
| Number of Inserts (No.): | 6 |
| Replacement Insert Tips: | (L065) |
| Nett Weight (kg): | 1.85 |



Description

SUPER HIGH-RAKE FACE MILL - 100mm x 45°
Use carbide inserts (ISO) SEKT1204 (L065)
NOTE: Carbide Inserts not included

Features

- Suitable for low horsepower machines where rapid metal removal is required.
- Suitable for steel, cast iron and non-ferrous metals
- Positive rake

Includes

- Lock key for insert

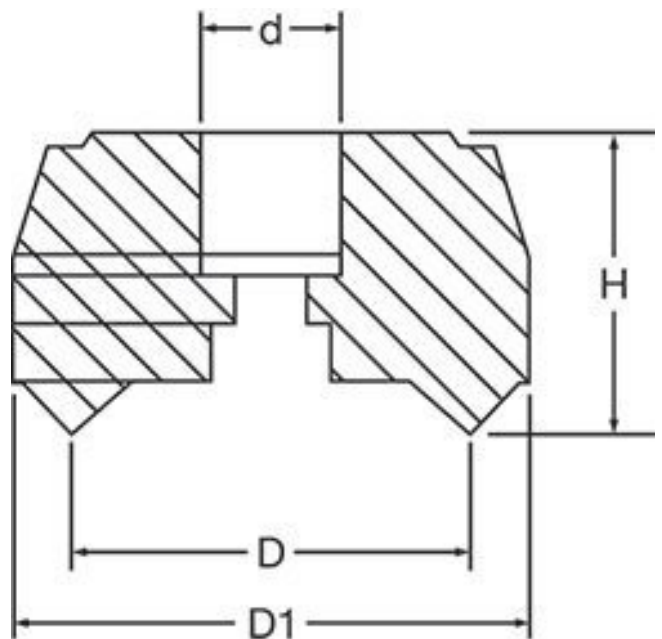

Product Brochure For M518

Recommended Accessories

L065
KYOCERA Carbide Inserts -
Milling



ML090
Cutter Part - Screw



L538
Key to Suit Tool Holder



M537
Face Mill Arbor



M544
Face Mill Arbor

M554
Face Mill Arbor

T158
BT40-FMB32-45 Face Mill Arbor

