

Product Brochure For M213

NT30 Horizontal Milling Attachment - HMA-386

Suits Ø86mm Quill

On Sale

Ex GST	Inc GST
\$1,574.00	\$1,810.10
\$1,339.13	\$1,540.00

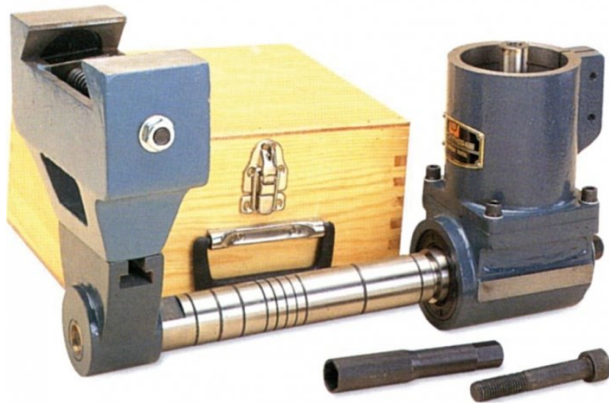

ORDER CODE:	M213
MODEL:	HMA-386
Taper:	NT30
Quill Diameter (mm):	Ø86
Maximum Speed (rpm):	2000
A (deg):	50°
B (mm):	140 - 170
C (mm):	175
D (mm):	160
E (mm):	270
F (mm):	230
G (mm):	45
Nett Weight (kg):	30



Description

Manufactured in Taiwan

Used on vertical milling machine where horizontal work is required. Designed to simplify right angle work without the need for special tooling or complex fixtures.

Note! If using with an air powered drawbar the drive motor of the drawbar needs to be removed as the quill is lowered so that the horizontal attachment can be secured. As the quill is lowered the air drawbar is dis-engaged and cannot be used. For this application use a standard drawbar.

Features

- Arbor support suits dovetail widths of 140-170mm
- Supplied in deluxe wooden case
- Arbor Ø1" x 12" in length

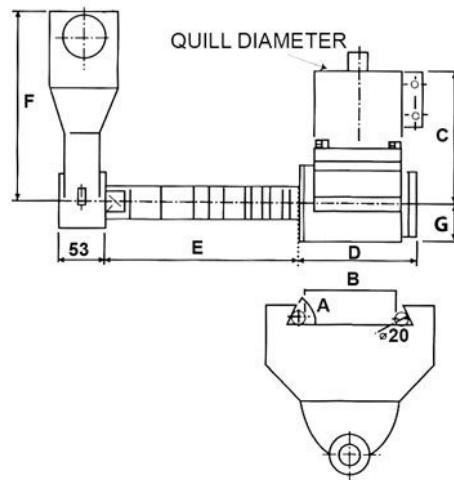

Product Brochure For M213

Recommended Accessories

M603D

Industrial Turret Milling Machine

M607D

Industrial Turret Milling Machine

