

Product Brochure For M1833

Precision Boring Head - BC-3

Ø75mm Head

Requires Spindle Arbor To Suit Machine



Description

Sturdy boring head suitable for roughing & finishing work. Fitted with 2 vertical and one cross hole for the boring bars. The boring head allows the boring bar to be adjusted at a right angle to the spindle axis. This feature makes it possible to position the boring cutter accurately to bore holes of varying diameters. The adjusting screw is hardened & ground and is a non reflecting satin chrome. The reading dial allows for adjustments of 0.01mm on the tool slide and is a direct reading.

Features

- Wide range of boring diameters and depths
- Calibrated micro adjusting screw via a hexagon key.
- 1-1/2" x 18TPI threaded body to mount optional arbors
- Accepts 18mm diameter boring bars
- Includes storage case for protection

| | |
|-------------------------------------|--------|
| ORDER CODE: | M1833 |
| MODEL: | BC-3 |
| Type: | Boring |
| D (mm): | 75 |
| H (mm): | 80 |
| d (lowercase) (mm): | 18 |
| W (mm): | ~ |
| h (lowercase) (mm): | ~ |
| Cross Hole Diameter (mm): | ~ |
| Centre Distance Between Holes (mm): | 23 |
| Micro Adjustment Travel (mm): | 25 |
| Nett Weight (kg): | 3.2 |

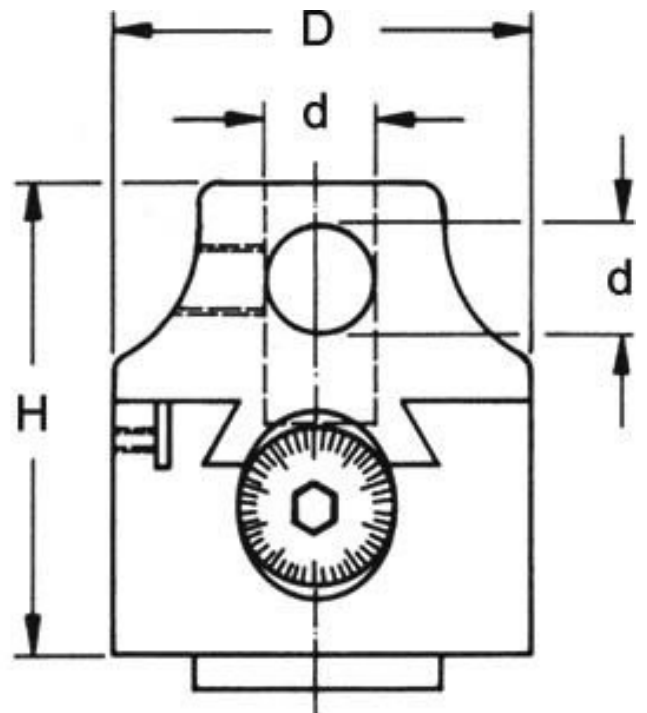

Product Brochure For M1833

Recommended Accessories

M181
Boring Bar Set - 12 piece



M181A
Boring Bar Set - 4 piece



M192
Boring Head Shank



M190
Boring Head Shank



M193
Boring Head Shank



M194
Boring Head Shank

