

Product Brochure For M081

unit: mm

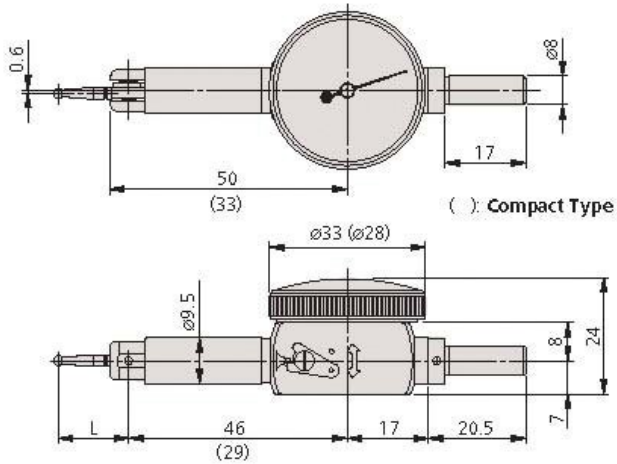

Mass: 45g (40g)
() : Compact Type

Specific Features



Parts

Product Brochure For M081

Recommended Accessories

M050
Magnetic Base - Standard



M051
Magnetic Base - Deluxe - One Lock



Q430
Magnetic Base - Small



Q435
Magnetic Base - Large



Q4351
Magnetic Base - Large



Q436
Magnetic Base - One Lock (Large)

