

Product Brochure For L600D

Centre Lathe - CL-410

Ø410 x 1000mm Turning Capacity - Ø58mm Spindle Bore
Includes Digital Readout System & Quick Change Toolpost

58mm Bore & 300mm Wide Bed



ORDER CODE:	L600D
MODEL:	CL-410
Swing Over Bed (mm):	410
Distance Between Centres (mm):	1000
Spindle Bore (mm):	58
Swing In Gap (mm):	640
Swing Over Cross-slide (mm):	224
Digital Readout System Fitted:	Yes
Quick Change Toolpost Fitted:	Yes
Leadscrew Covers Fitted:	Yes
Taper Turning Attachment:	~
Coolant System:	Yes
Tool Height To Suit (mm):	25
Centre Height (mm):	205
Spindle Nose Size or Type:	D1-6 Camlock
Bed Width (mm):	300
Headstock Spindle Taper (MT):	6
Tailstock Taper (MT):	4
Cross Slide Travel (mm):	290
Compound Slide Travel (mm):	128
Leadscrew Type:	Metric
Metric Cross Feed (X-Axis) (mm/rev):	0.014 - 0.784
Imperial Cross Feed (X-Axis) (inch/rev):	~
Metric Longitudinal Feed (Z-Axis) (mm/rev):	0.031 - 1.70
Imperial Longitudinal Feed (Z-Axis) (inch/rev):	~
Metric Thread Steps & Pitch (No. / mm):	41 (0.1 - 14)
Imperial Thread Steps & TPI (No. / TPI):	60 (2 - 112)
3 Jaw Chuck Diameter (mm):	250
4 Jaw Chuck Diameter (mm):	250
Spindle Steps / Speeds (No. / rpm):	12 (25 - 2000)
Motor Power (kW / hp):	5.5 / 7.5
Voltage / Amperage (V / amp):	415
Nett Weight (kg):	1850

Features

- 2 axis digital readout system
- Quick change toolpost
- Triple bearings supporting headstock spindle
- Adjustable taper roller bearings providing spindle accuracy
- Precision 'V'-beds & headstock gears are all hardened & ground
- Automatic lubrication pump for saddle & cross slides
- One piece cast iron base increases rigidity
- Overload protection on drive motor and coolant system
- Universal enclosed gearbox incorporating metric & imperial thread capabilities
- Inching button incorporated on the control panel for convenient spindle speed selection
- Foot operated spindle brake with safety cut out switch
- 300mm wide induction hardened heavy duty cast iron bed
- Removable gap bed allowing work piece to swing up to 640mm
- Chuck guard fitted with safety micro switch
- Powered longitudinal and cross feeds
- Adjustable 5 position length-stop mechanism for accurate repetitive operation
- Dual calibrated dials incorporating metric & imperial graduations
- Coolant system with flexible hose enabling operator to manipulate flow direction
- Oil sight glass for head stock and gearbox
- Low voltage halogen work light
- D1-6 camlock spindle for quick chuck removal
- 12 spindle speeds from 25-2000rpm

Product Brochure For L600D

- Large 58mm spindle bore
- 5.5kW / 7.5HP 415V main motor

Includes

- 2 axis digital readout system
- Quick change toolpost
- 250mm 3-jaw chuck with reverse jaws
- 250mm 4-jaw chuck
- Fixed Steady with roller bearings
- Travelling steady with brass guides
- Concertina leadscrew covers
- Faceplate
- Dead centres
- Thread chasing dial
- Foot brake
- Coolant system
- Work light
- Rear splash guard
- Spindle reducing bush

Specific Features



Left View



2 Axis Digital Readout



Chuck Guard With Micro



Headstock Controls



Spindle Speed Levers



Gearbox Levers

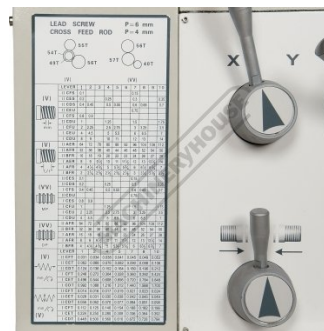

Thread and Feed Chart



Quick Change Toolpost



Auto Lubrication Pump



Saddle Safety Guard



Saddle Safety Guard Shown Open



Compound Slide

Product Brochure For L600D



Leadscrew Covers



Thread Chasing Dial

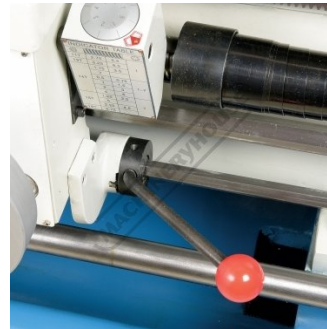

Spindle Engagement Lever



5 Position Adjustable Length Stop

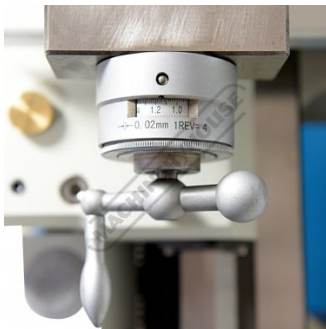

Compound Slide Dial in Metric Mode



Compound Slide Dial in Imperial Mode



Cross Feed Dial In Metric Mode



Cross Feed Dial In Imperial Mode

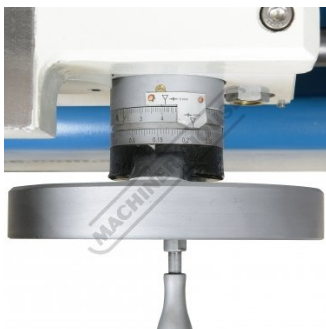

Saddle Dial

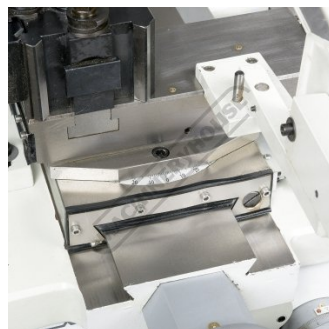

Compound Angle Scale



Saddle Controls



Hardened & Ground Bedways



58mm Spindle Bore



Removable Gap Bed



Fixed Steady With Roller Guides



Travelling Steady With Roller Guides

Product Brochure For L600D



LED Worklight & Coolant Hose



LED Worklight Close Up



Tailstock



Tailstock Quill Graduations



Tailstock with Adjustable Horizontal Movement



Tailstock Dial in Metric Mode



Tailstock Dial in Imperial Mode



Foot Brake



Main Switch

Product Brochure For L600D

Recommended Accessories

L048
 Right Hand Turning Tool Holder

L049
 Left Hand Turning Tool Holder

L041
 Right Hand Turning Tool Holder

L042
 Left Hand Turning Tool Holder



L453
 Lathe Turning Tool Kit - 3 piece
 Insert Type

L459
 Lathe Threading Tool Kit - Insert
 Type

L467
 Professional Lathe Parting Tool
 Kit - Insert Type

C046
 4MT Pipe Centre - 70° Cone



Product Brochure For L600D

C290
Heavy Duty Drill Chuck - Keyed Type



C294
Industrial Drill Chuck - Keyless Type



D454A
4MT x JT3 Drill Chuck Arbor



D424
Drill Sleeve - Morse Taper



D422
Drill Sleeve - Morse Taper



D1272
Metric 135° Precision HSS Drill Set - 25 Piece



D1282
Imperial 135° Precision HSS Drill Set - 29 Piece



D126
Metric 135° Precision HSS Drill Set - 170 Pieces



D119
Metric 2MT HSS Drill Set



S090A
Soluble Metal Cutting Fluid - 1 Litre



S090
Soluble Metal Cutting Fluid - 5 Litre



S076
Cutting Tool Lubricant Fluid - 500ml



Product Brochure For L600D

S077

Drilling, Tapping & Cutting Tool
Lubricant Spray - 400g



S074

Cutting Tool Lubricant Paste -
500g



S091

Soluble Metal Cutting Fluid - 20
Litre



G660

Lathe Leadscrew Cover Kit



A358

Sky Hook Lifting Device



A358A

Chuck Hook



L300

Magnetic Swarf Remover



M9991

Magnetic Floor Sweeper



M800

Rubber Mat - Anti-Fatigue



M805

Rubber Mat - Anti-Fatigue

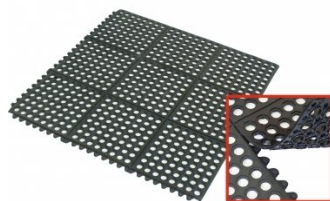

O043

Rust & Corrosion Preventive



O042

General Purpose Lubricant &
Corrosion Inhibitor



Product Brochure For L600D

O044

Rust & Corrosion Preventive

