

## Product Brochure For L297

### Quick Change Toolpost - Model C

280mm Lathe Centre Height



**Ex GST**                      **Inc GST**  
**\$1,038.00**                **\$1,193.70**

ORDER CODE:	L297
MODEL:	C
Lathe Centre Height (mm):	280
Lathe Swing (mm):	560
A (mm):	21
B (mm):	19
C (mm):	108
D (mm):	145
E (mm):	~
H (mm):	51 - 72
h (mm):	94
S (mm):	38
T (mm):	32
Y (mm):	~
Number of Sides (No.):	3
Number of Holders (No.):	5
Nett Weight (kg):	26



#### Description

Manufactured from carbonized and hardened steel.  
Italian design style.

#### Features

- All bearing surfaces are precision ground to ensure rigidity
- Handy lathe accessory for tool rooms and general engineering shops
- Ease of operation cuts set-up time by 90%
- No shims are required to adjust tools to correct centre height
- Easily fitted to most centre lathes
- Please Note: Some machining required to suit your lathe

#### Includes

- 4 x Square Tool Holders - for 32mm tools
- 1 x Vee Tool Holders - for boring bars

#### Optional Accessories

- Holders - L297A

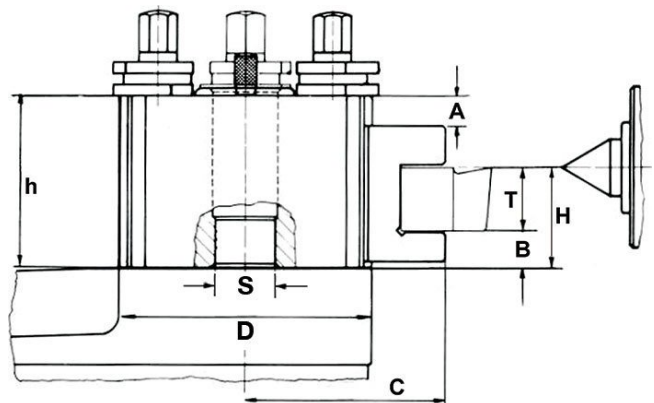

## Product Brochure For L297

---

### Recommended Accessories

L297A

Quick Change Toolpost Holder -  
Std



L2902

Toolpost T-Handle

