

Product Brochure For L295

Quick Change Toolpost - QA-150

150 - 170mm Lathe Centre Height

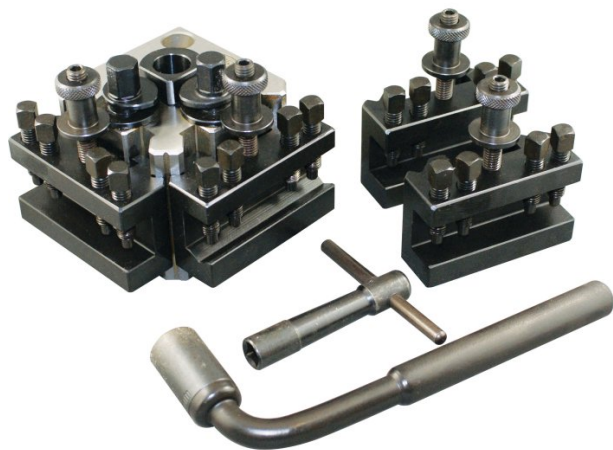

Ex GST	Inc GST
\$720.00	\$828.00

ORDER CODE:	L295
MODEL:	QA-150
Lathe Centre Height (mm):	150 - 170
Lathe Swing (mm):	300 - 340
A (mm):	15
B (mm):	20
C (mm):	60
D (mm):	74
E (mm):	~
H (mm):	28 - 41
h (mm):	60
S (mm):	24
T (mm):	16
Y (mm):	~
Number of Sides (No.):	2
Number of Holders (No.):	4
Nett Weight (kg):	6.2



Description

Manufactured in Taiwan

Manufactured from carbonized and hardened steel.
Italian design style.

Features

- All bearing surfaces are precision ground to ensure rigidity
- Handy lathe accessory for tool rooms and general engineering shops
- Ease of operation cuts set-up time by 90%
- No shims are required to adjust tools to correct centre height
- Easily fitted to most centre lathes
- Please Note: Some machining required to suit your lathe

Includes

- 3 x Square Tool Holders - for 16mm tools
- 1 x Vee Tool Holders - for boring bars

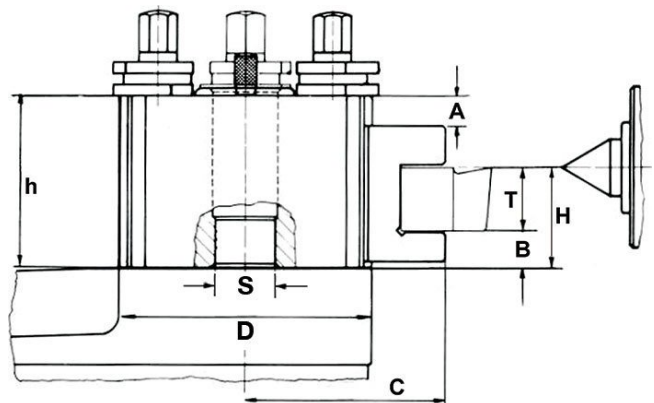

Product Brochure For L295

Recommended Accessories

L295A

Quick Change Toolpost Holder - Std



L290

Toolpost T-Handle



L237

Centre Lathe



L237D

Centre Lathe



L201

Centre Lathe



L201D

Centre Lathe



L240D

Centre Lathe



L242D

Centre Lathe

