

Product Brochure For L293

Quick Change Toolpost - Model A

168mm Lathe Centre Height



ORDER CODE:	L293
MODEL:	A
Lathe Centre Height (mm):	168
Lathe Swing (mm):	336
A (mm):	10
B (mm):	12
C (mm):	75
D (mm):	100
E (mm):	~
H (mm):	32 - 42
h (mm):	60
S (mm):	24
T (mm):	20
Y (mm):	~
Number of Sides (No.):	3
Number of Holders (No.):	6
Nett Weight (kg):	11.4

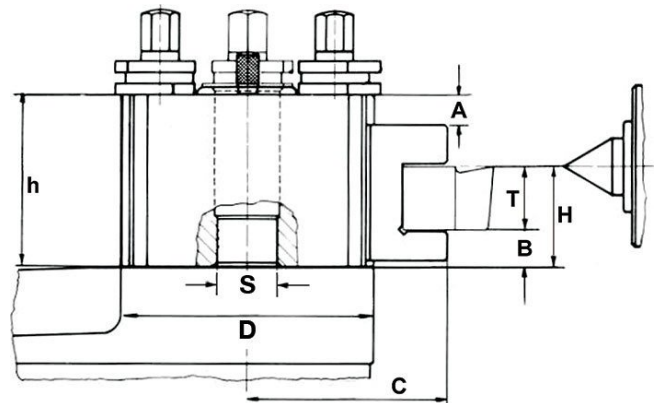

Description

Manufactured from carbonized and hardened steel.
Italian design style.

Features

- All bearing surfaces are precision ground to ensure rigidity
- Handy lathe accessory for tool rooms and general engineering shops
- Ease of operation cuts set-up time by 90%
- No shims are required to adjust tools to correct centre height
- Easily fitted to most centre lathes
- Please Note: Some machining required to suit your lathe

Includes

- 5 x Square Tool Holders - for 20mm tools
- 1 x Vee Tool Holders - for boring bars

Optional Accessories

- Holders - L293A

Product Brochure For L293

Recommended Accessories

L293A

Quick Change Toolpost Holder -
Std

L290

Toolpost T-Handle

