

Product Brochure For L0522

KENNAMETAL Carbide Inserts - Turning - VBGT 160404 HP

Grade KC5410 - Aluminium

5 Inserts Per Pack



ORDER CODE:	L0522
MODEL:	VBGT 160404 HP
Grade:	KC5410
Application:	Aluminium
Pieces in Set (Qty):	5
[D] Insert IC Size (Inscribed Circle) (mm):	9.53
[D1] Insert Hole Size (mm):	4.4
[L10] Insert Cutting Edge Length (mm):	16.61
[S] Insert Thickness (mm):	4.76
[R?] Corner Radius (mm):	0.4
Relief Angle (Deg):	5
d (mm):	~
Insert shape (Style):	Diamond (Rhombic)

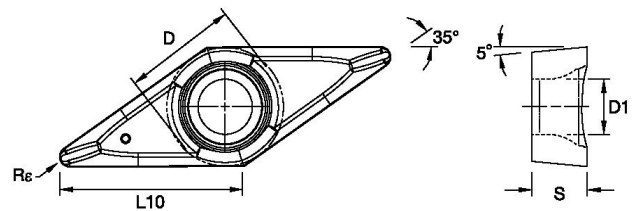

Description

KC5410 Grade - Aluminium

Manufactured in Germany, the KENNAMETAL KC5410 HP insert is designed for high-performance machining of aluminium and other non-ferrous materials. Its premium PVD-coated carbide grade provides excellent wear resistance, smooth chip flow and superior surface finishes. Ideal for roughing, semi-finishing and finishing operations, it also performs well on nylon and plastics.

The "HP" indicates a high-positive, light-feed chipbreaker designed to achieve excellent finishes and prevent built-up edges.

Features

- Made in Germany for exceptional quality and precision.
- Premium PVD-coated insert on a highly deformation-resistant unalloyed substrate for extended tool life.
- Optimised high-positive cutting geometry ensures smooth cutting action, reduced cutting forces and excellent chip control
- Specifically designed for high-performance turning of aluminium. Also suitable for machining nylon, plastics and timber
- Supplied in a convenient pack of 5 inserts

Product Brochure For L0522

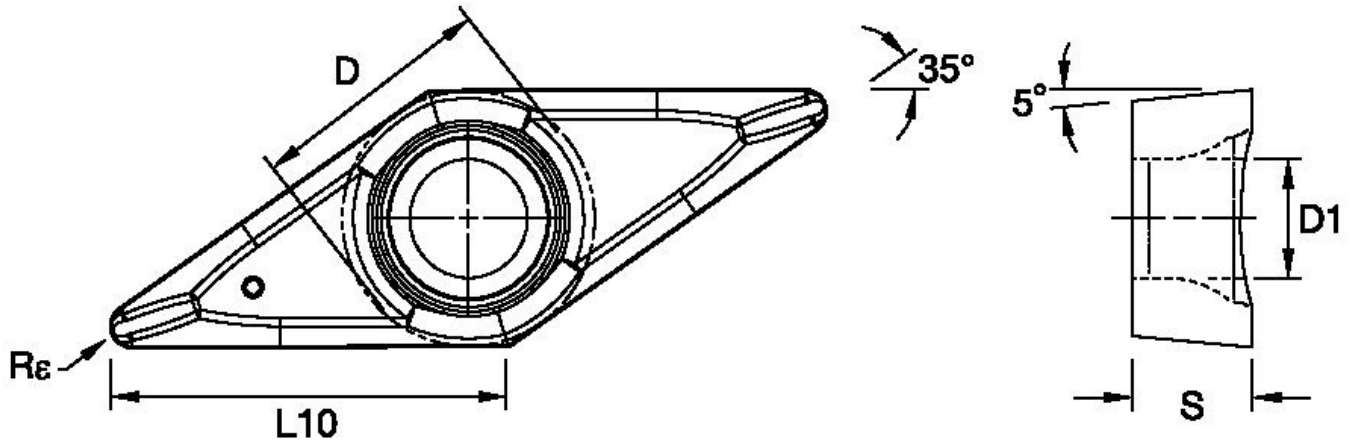

Specific Features



Tip

Recommended Accessories

L4062
93° Rhombic / Positive - Right
Hand Turning Tool Holder

L4064
93° Rhombic / Positive - Right
Hand Turning Tool Holder

L5225
Seat Pin to Suit Tool Holder

L5227
WRENCH to Suit Tool Holder



Product Brochure For L0522

L5224
SCREW to Suit Tool Holder



L538
Key to Suit Tool Holder

