

Product Brochure For L0521

35° Rhombic Positive Turning Insert - VCMT160404HQ

Grade CA125P - General Purpose Steel
10 Inserts Per Pack

Ex GST
\$230.00

Inc GST
\$264.50

ORDER CODE:	L0521
MODEL:	VCMT160404HQ
Grade:	CA125P
Application:	General Purpose Steel
Pieces in Set (Qty):	10
[D] Insert IC Size (Inscribed Circle) (mm):	9.53
[D1] Insert Hole Size (mm):	4.4
[L10] Insert Cutting Edge Length (mm):	~
[S] Insert Thickness (mm):	4.76
[R?] Corner Radius (mm):	0.4
Relief Angle (Deg):	7°
d (mm):	~
Insert shape (Style):	~

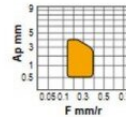
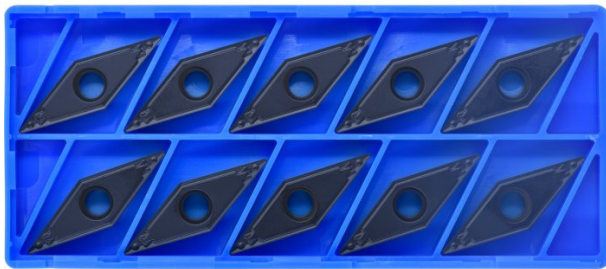

l
16.5 mm

d
9.52 mm

s
4.76 mm

r
0.4 mm

KYOCERA
JAPANESE CARBIDE



Description

CA125P Grade CVD Coated Carbide for Steel
Suitable for continuous to heavy interrupted machining, these inserts are designed for general-purpose applications.

HQ Chipbreaker
General purpose chipbreaker for medium machining.

Features

- Japanese Made
- CVD Coated Carbide with Thin Ultra-fine TiCN Coating
- 10 Inserts Per Pack

Product Brochure For L0521

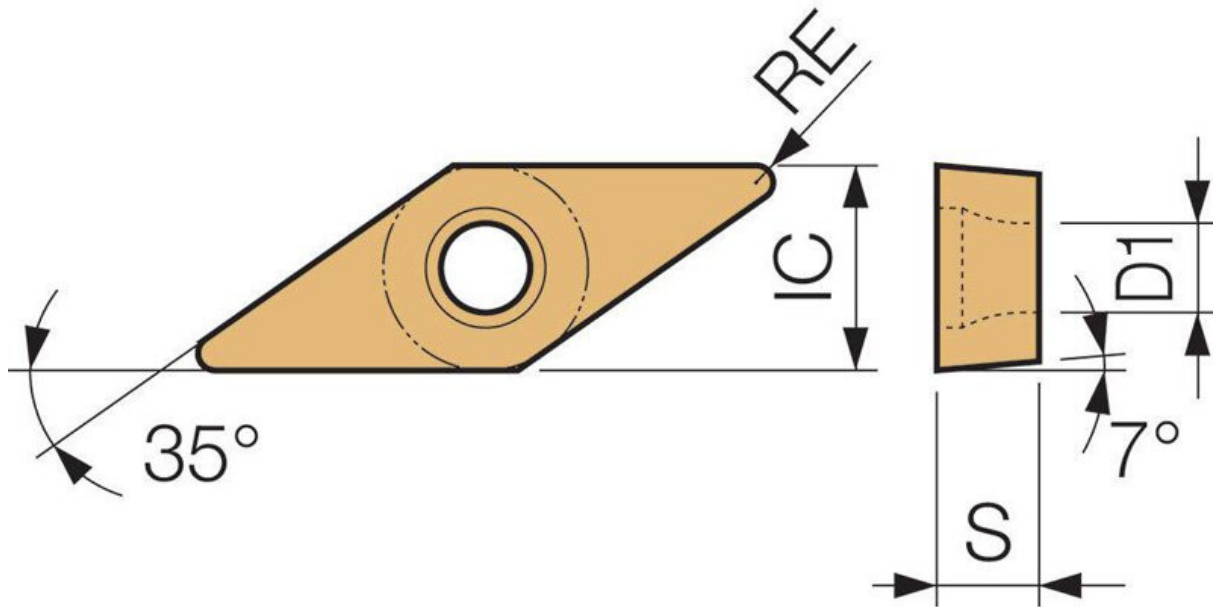

Specific Features

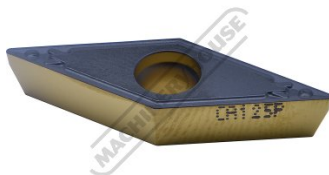

Side View

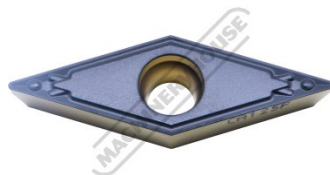

Top View



Bottom View

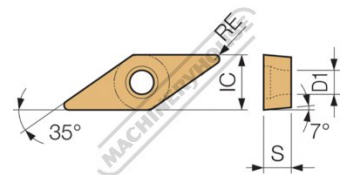

Diagram

Product Brochure For L0521

Recommended Accessories

L4062

93° Rhombic / Positive - Right
Hand Turning Tool Holder

L4064

93° Rhombic / Positive - Right
Hand Turning Tool Holder

