

Product Brochure For H255

## Electric Chain Hoist - TECH0206

2 Tonne x 6 Metre Lift  
Two Speed: 3m/min. Lift Speed



**On Sale - Special Order**

Ex GST	Inc GST
<del>\$3,700.00</del>	<del>\$4,255.00</del>
<b>\$3,582.61</b>	<b>\$4,120.00</b>

ORDER CODE:	H255
MODEL:	TECH0206
Capacity (Tonne):	2
Lift Height (Metre):	6
Lift Speed (m/min):	3
Motor Power (W):	1200
Voltage (V):	240



### Description

Thermal Prevention Device Fitted

### Features

- Light weight, compact design with high efficiency motor
- Pressed steel structure, high strength body
- High tensile alloy steel top & bottom hooks
- Grade 80 - 7.1mm Alloy Steel load chain
- Limit switches fitted at top and bottom ends to prevent chain run-out
- 240V , 50Hz Dual speed Motor 1200 Watts

### Optional Accessories

- Available with customisable chain lengths and an optional wireless remote for added convenience (additional costs may apply)

# Main Dimension of TECH Series Electric Chain Hoist

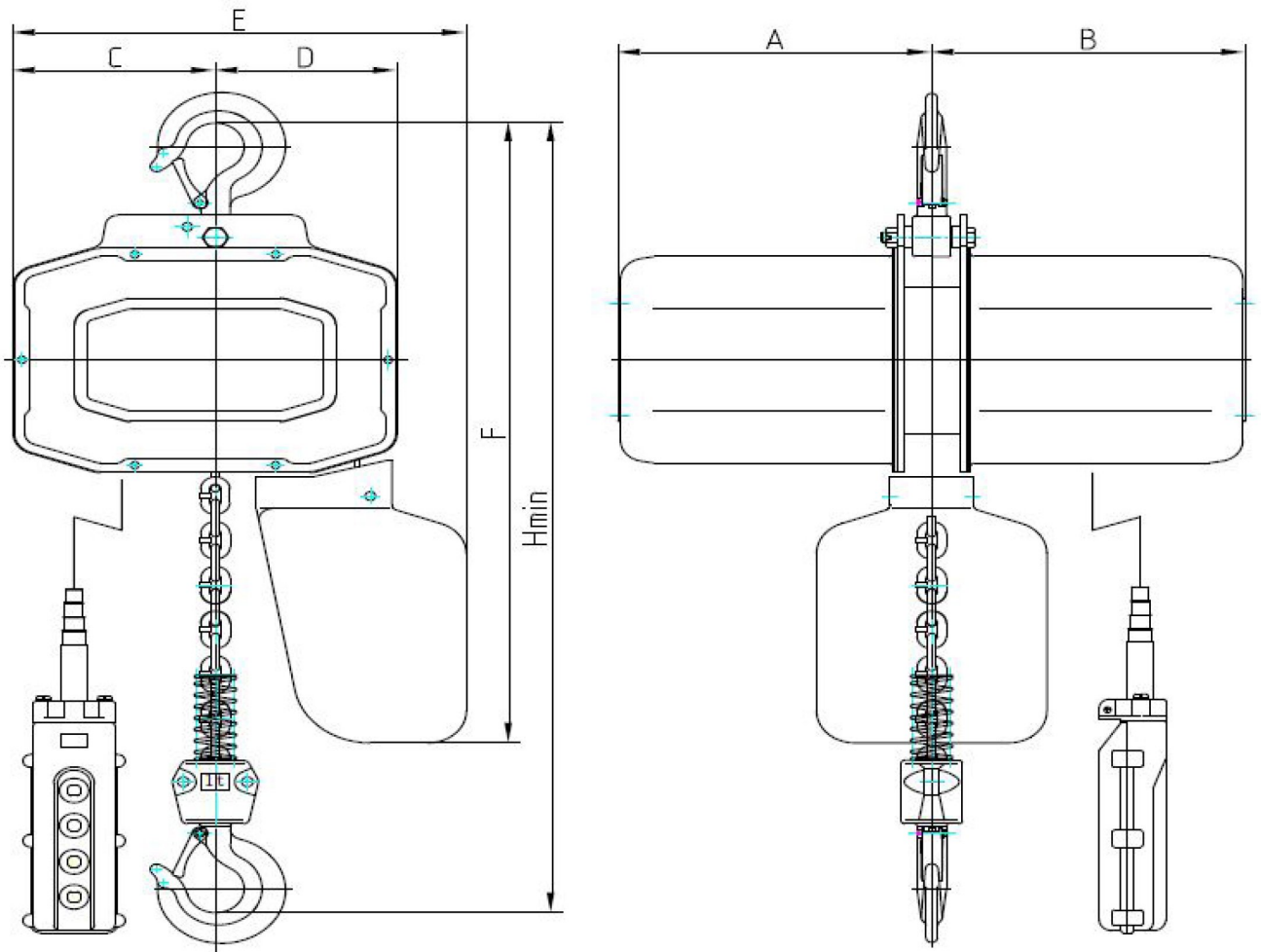

Model	TECH0103 / TECH0106	TECH0203 / TECH0206
A	245	245
B	245	245
C	158	124
D	142	176
E	350	350
F	600	610
H	520	630

Product Brochure For H255

**Recommended Accessories**

C148  
Girder Trolley



H352  
13mm 2T Grade S - Lifting Bow  
Shackle



H310  
Round Sling



H314  
Round Sling



H312  
Round Sling



H322  
Flat Sling



H324  
Flat Sling

