

Product Brochure For H254

Electric Chain Hoist - TECH0203

2 Tonne x 3 Metre Lift
Two Speed: 3m/min. Lift Speed



Special Order

Ex GST	Inc GST
\$3,480.00	\$4,002.00

ORDER CODE:	H254
MODEL:	TECH0203
Capacity (Tonne):	2
Lift Height (Metre):	3
Lift Speed (m/min):	3
Motor Power (W):	1200
Voltage (V):	240



Description

Thermal Prevention Device Fitted

Features

- Light weight, compact design with high efficiency motor
- Pressed steel structure, high strength body
- High tensile alloy steel top & bottom hooks
- Grade 80 - 7.1mm Alloy Steel load chain
- Limit switches fitted at top and bottom ends to prevent chain run-out
- High quality chain 7.1mm diameter
- 240V , 50Hz Dual speed Motor 1200 Watts

Optional Accessories

- Available with customisable chain lengths and an optional wireless remote for added convenience (additional costs may apply)

Main Dimension of TECH Series Electric Chain Hoist

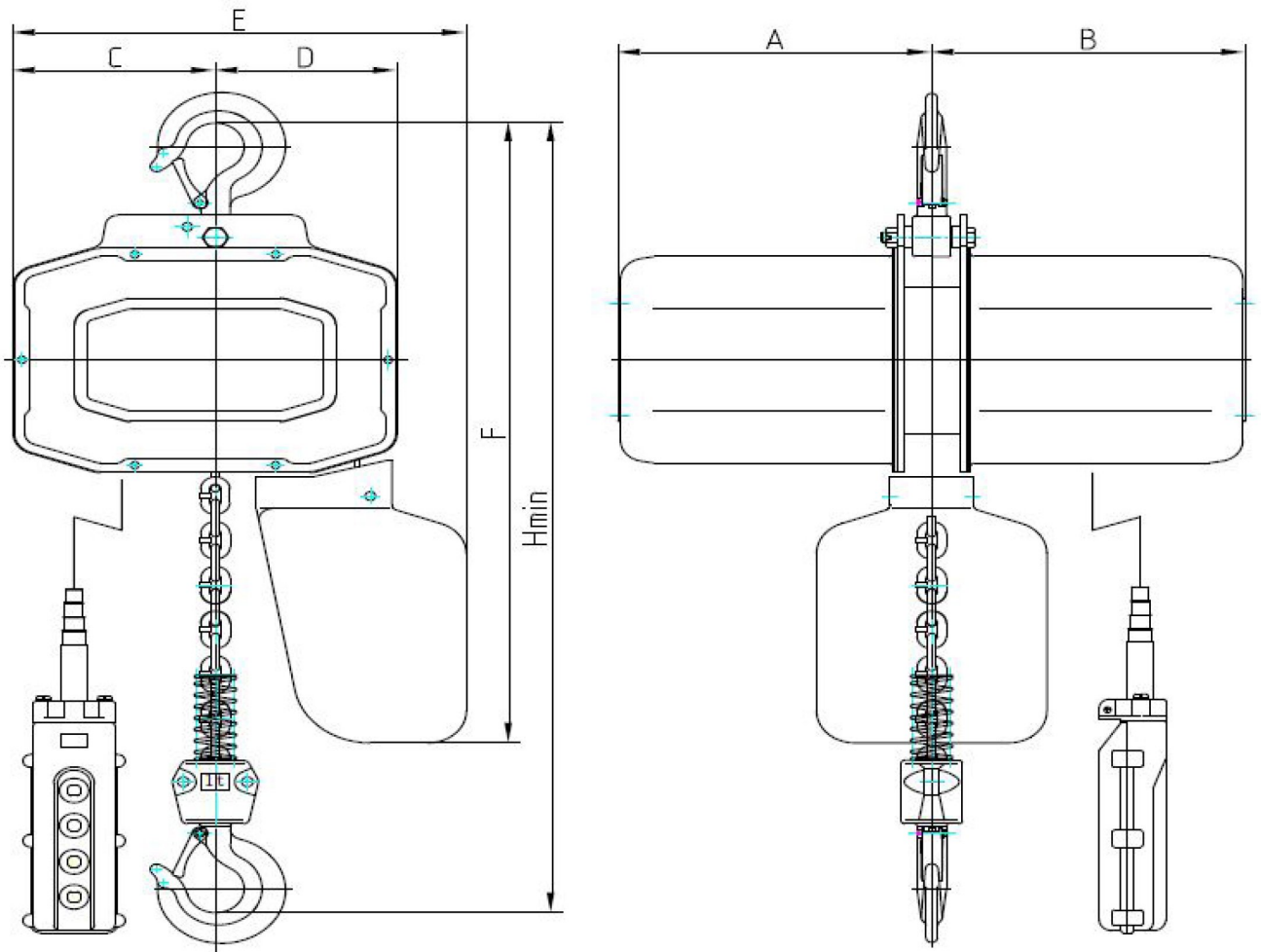

Model	TECH0103 / TECH0106	TECH0203 / TECH0206
A	245	245
B	245	245
C	158	124
D	142	176
E	350	350
F	600	610
H	520	630

Product Brochure For H254

Recommended Accessories

C148
Girder Trolley



H310
Round Slings



H314
Round Slings



H312
Round Slings



H322
Flat Slings



H324
Flat Slings



H352
13mm 2T Grade S - Lifting Bow Shackle

