

Product Brochure For H250

## TECH0103 - Electric Chain Hoist

1 Tonne x 3 Metre Lift  
Single Speed: 6m/min. Lift Speed



<b>Ex GST</b>	<b>Inc GST</b>
<b>\$2,650.00</b>	<b>\$3,047.50</b>

ORDER CODE:	H250
MODEL:	TECH0103
Capacity (Tonne):	1
Lift Height (Metre):	3
Lift Speed (m/min):	6
Motor Power (W):	1200
Voltage (V):	240



### Description

Thermal Prevention Device Fitted

### Features

- Light weight, compact design with high efficiency motor
- Pressed steel structure, high strength body
- High tensile alloy steel top & bottom hooks
- Grade 80 - 7.1mm Alloy Steel load chain
- Limit switches fitted at top and bottom ends to prevent chain run-out
- 240V , 50Hz Single speed Motor 1200 Watts

# Main Dimension of TECH Series Electric Chain Hoist

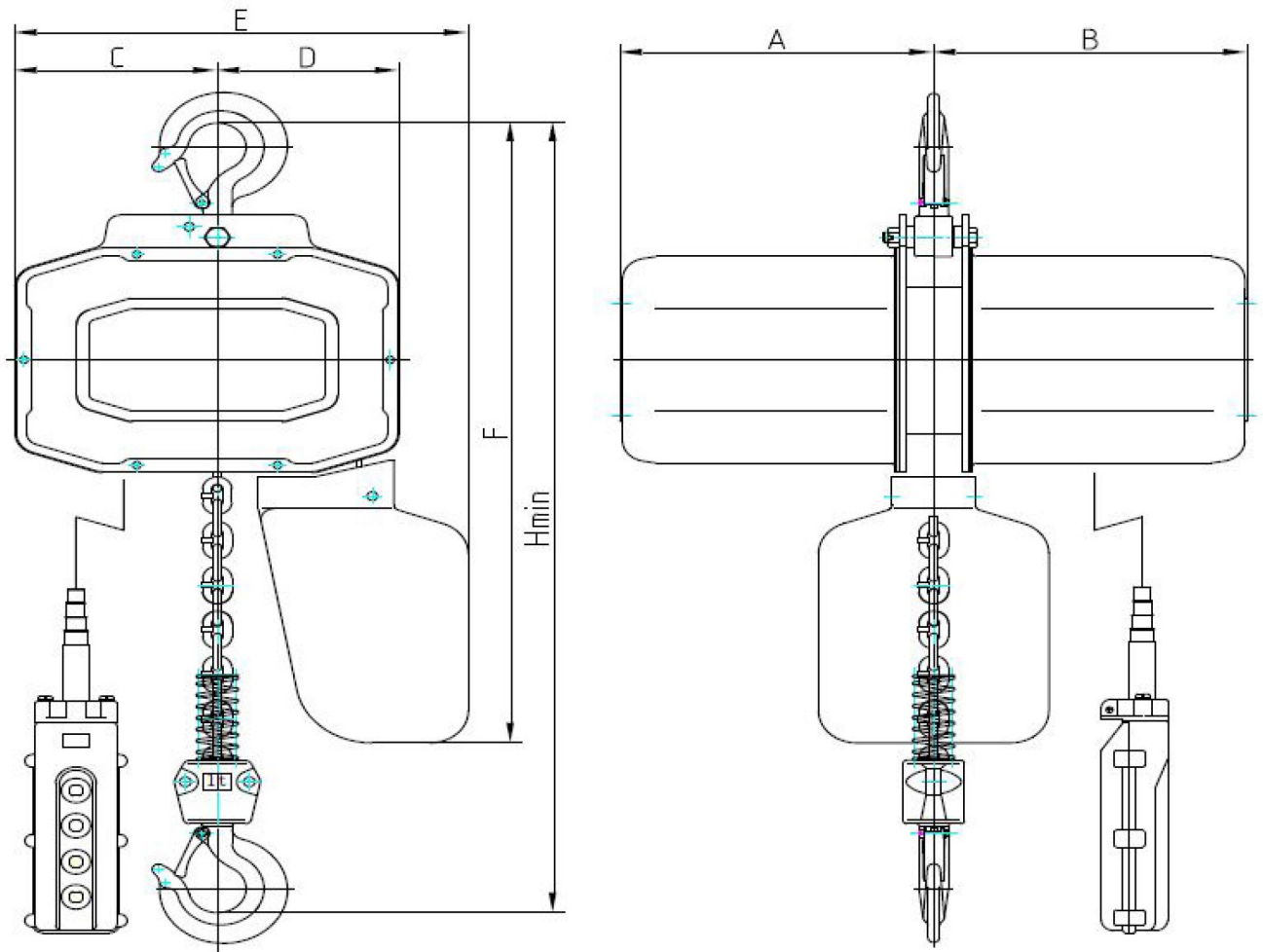

Model	TECH0103 / TECH0106	TECH0203 / TECH0206
A	245	245
B	245	245
C	158	124
D	142	176
E	350	350
F	600	610
H	520	630

Product Brochure For H250

**Recommended Accessories**

C147  
Girder Trolley



H300  
Round Sling



H316  
Flat Sling



H305  
Round Sling



H318  
Flat Sling



H308  
Round Sling



H307  
Round Sling



H320  
Flat Sling



Product Brochure For H250

---

H310  
Round Sling



H314  
Round Sling



H322  
Flat Sling



H312  
Round Sling



H324  
Flat Sling

