

Product Brochure For E092

2HP Electric Motor - EM2-14

1440rpm, Ø19mm Shaft



On Sale

Ex GST	Inc GST
\$416.00	\$478.40
\$334.78	\$385.00

ORDER CODE:	E092
MODEL:	EM2-14
Motor Power (kW / hp):	1.5 / 2
Speed (rpm):	1440
Shaft Diameter (mm):	Ø19
Reversible Motor (Yes / No):	Yes
Fan Cooled (Yes / No):	Yes
Voltage (V):	240
Amps Required:	10
Input Power Supply Connection:	Includes Plug & Lead



Description

Suited for most general applications.

Features

- 240V motor
- TEFC - (Totally enclosed fan cooled)
- Reversible motor shaft direction
- Thermal overload with manual reset
- Foot mounted

Product Brochure For E092

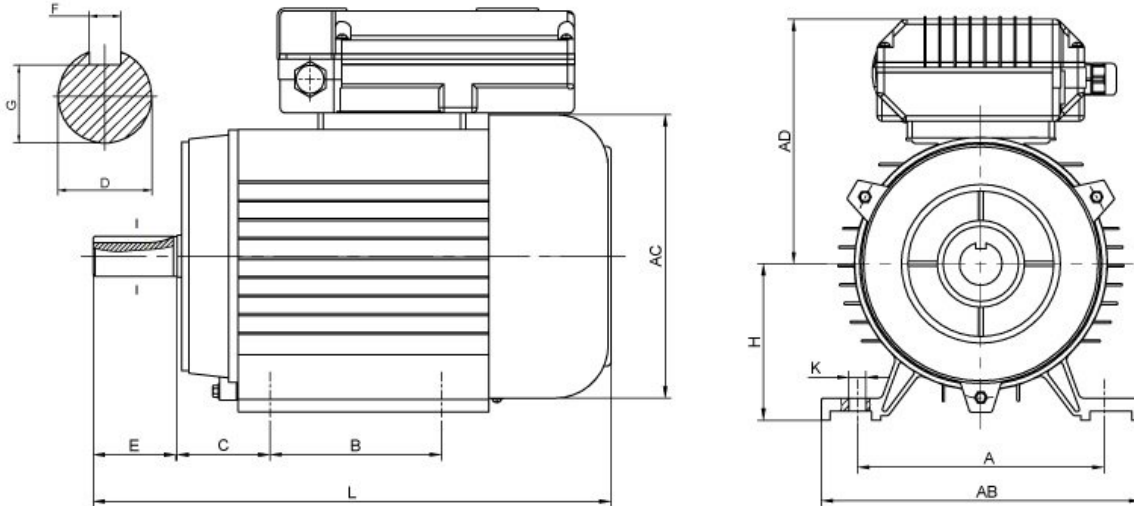

Model	Mounting Dimensions (mm)									Overall Dimensions (mm)			
	A	B	C	D	E	F	G	H	K	AB	AC	AD	L
EM1-14	125	100	50	15.9	40	4.8	13	80	10	155	156	160	295
EM25-28	140	100	56	19	50	6	16	90	10	168	174	155	320
EM2-14	140	125	56	19	50	6	16	90	10	168	174	155	345
EM3-28	140	125	56	19	50	6	16	90	10	168	174	155	345

Specific Features



Shown with Lead

SINGLE PHASE INDUCTION MOTOR				CE
FRAME	MEC90	POWER	2HP	
VOLTS	240V/50HZ	AMPS	8.8	
R.P.M.	1440	INS.CLS.	B	
RATING	COMP.	40uF/450V	150uF/350V	
IP54	MANUAL RESET OVERLOAD			
DATE	2011-09			

Specification