

Product Brochure For C7002

High Precision 3 Jaw Self Centering Lathe Chuck - SK-4

Ø112mm

Front or Rear Back Plate Mount

Special Order

Ex GST

Inc GST

\$732.00

\$841.80



ORDER CODE:	C7002
Model:	SK-4
Chuck Size (mm):	Ø112
Bore / Through Hole Size (mm):	Ø32
Mounting Type:	Back Plate
Gripping Force ((kgf)):	1200
Gripping Range OD (mm):	Ø3 - 95
Gripping Range ID (mm):	Ø34 - 90
Max Speed Rating (rpm):	2500
Nett Weight (Kg):	3.8

Strong



Description

Auto Strong are one of the world's leading manufacturers of lathe chucks. The SK Series are manufactured in Taiwan with a high precision gripping accuracy of 0.03mm and with a Meehanite casting body they are suitable for high-speed applications.

Features

- 3 Jaw self centering lathe chuck
- High precision gripping accuracy of 0.03mm (0.0012") T.I.R
- 2 Piece hard jaws could be used as internal jaws and external jaws
- Meehanite chuck body suitable for high speed (Max. 2500rpm)
- Plain back suitable for front or rear back plate mounting
- Optional bolt on soft jaws are available

Includes

- Chuck key

Product Brochure For C7002

3 Jaw Self Centring Precision Lathe Chucks

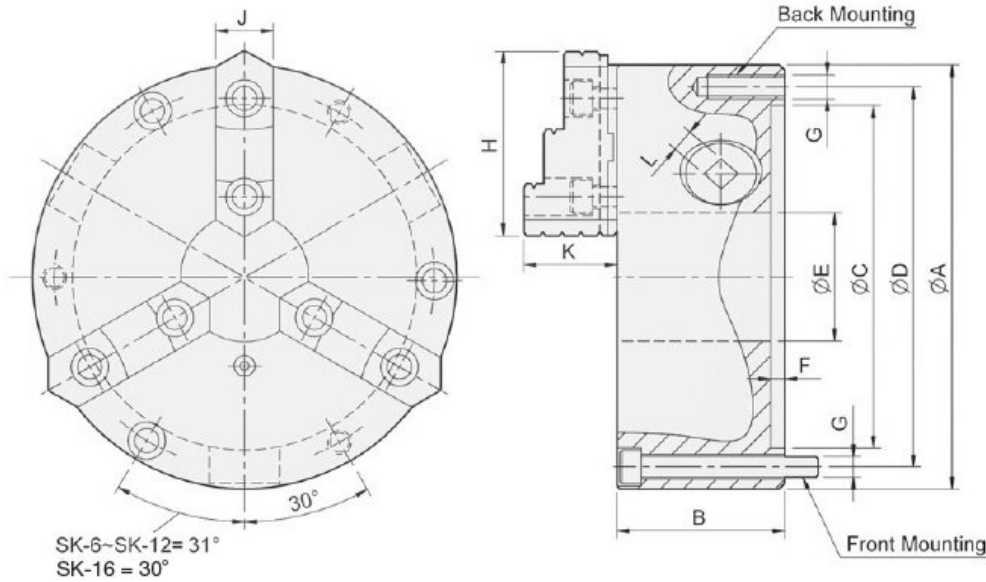

Order Code	Model	A	B	C	D	E	F	G		H	J	K	L	Allowable Handle Torque (kgf•m)	Gripping Force (kgf)	Moment Of Inertial (kg•m ²)	Max. Speed (r.p.m.)	Weight (kg)	Gripping Range	
								BACK	FRONT										O.D. Range	I.D. Range
C7002	SK-4	112	58	80	95	32	4.8	3-M8	3-M8x65	47	19	31.6	8	4.5	1200	~	2500	3.8	Ø3-Ø95	Ø34-Ø90
C7003	SK-6	167	67	130	147	45	5.5	3-M10	3-M10x70	72	26	40.2	10	9.0	2200	0.03	2000	9	Ø4-Ø160	Ø55-Ø150
C7005	SK-8	200	76.5	160	176	58	5.5	3-M10	3-M10x80	82	28	42	11	11.0	2500	0.07	2000	15.5	Ø8-Ø190	Ø68-Ø180
C7006	SK-9	232	84	190	210	70	6	3-M12	3-M12x90	90.9	32	51.2	12	15.0	3000	0.16	2000	22	Ø11-Ø220	Ø70-Ø210
C7007	SK-10	273	87	230	250	89	8	3-M12	3-M12x90	100.5	35	56.7	12	19.5	4000	0.26	1800	29.7	Ø12-Ø260	Ø80-Ø250
C7008	SK-12	310	96	260	285	105	7	3-M12	3-M12x110	114.5	40	56.8	14	21.0	4200	0.58	1800	43.5	Ø15-Ø300	Ø90-Ø290
C7010	SK-16	405	122	345	375	160	8.7	~	6-M14x130	148.6	50	76.1	15	25.0	4500	1.72	1500	98	Ø30-Ø380	Ø110-Ø360

Product Brochure For C7002

Specific Features



Back Plate Mount



Jaw Front Profile



Interchangeable Jaws



Optional Soft Jaws



Included Accessories

Recommended Accessories

C7016
Soft Jaw Set

C2862
Chuck Key

L287
D1-4 Camlock Back Plate

